

DECARBONISATION OPTIONS FOR THE DUTCH STEEL INDUSTRY

A. Keys, M. van Hout, B. Daniëls

25 november 2019



Decarbonisation options for the Dutch steel industry

© PBL Netherlands Environmental Assessment Agency; © ECN part of TNO

The Hague, 2019

PBL publication number: 3723

TNO project no. 060.33956 / TNO publication number: TNO 2019 P11483

Authors

Keys, A., van Hout, M., Daniëls, B.

MIDDEN project coordination and responsibility

The MIDDEN project (Manufacturing Industry Decarbonisation Data Exchange Network) was initiated and is also coordinated and funded by PBL and ECN part of TNO. The project aims to support industry, policymakers, analysts, and the energy sector in their common efforts to achieve deep decarbonisation. Correspondence regarding the project may be addressed to: K.M. Schure (PBL), Klara.Schure@pbl.nl, or A.W.N van Dril (TNO), Ton.vanDril@tno.nl

Production coordination

PBL Publishers

This publication is a joint publication by PBL and ECN part of TNO and can be downloaded from: www.pbl.nl/en. Parts of this publication may be reproduced, providing the source is stated, in the form: Keys, A, van Hout, M, Daniëls, B (2019), Decarbonisation options for the Dutch Steel Industry. PBL Netherlands Environmental Assessment Agency & ECN part of TNO, The Hague.

PBL Netherlands Environmental Assessment Agency is the national institute for strategic policy analysis in the fields of the environment, nature and spatial planning. We contribute to improving the quality of political and administrative decision-making by conducting outlook studies, analyses and evaluations in which an integrated approach is considered paramount. Policy relevance is the prime concern in all of our studies. We conduct solicited and unsolicited research that is both independent and scientifically sound.

ECN part of TNO has a twofold mission: to accelerate the energy transition and to strengthen the competitive position of the Netherlands. ECN part of TNO conducts independent and internationally leading research and we stand for an agenda-setting, initiating and supporting role for government, industry and NGOs.

This report was reviewed by TATA Steel IJmuiden. PBL and ECN part of TNO remain responsible for the content. The decarbonisation options and parameters are explicitly not verified by the companies.

Inhoud

Summary	4
Introduction	5
1 Current primary steel production	6
1.1 Steel industry in the Netherlands	6
1.2 Company overview	6
1.3 Production overview	6
2 Steel production processes	9
2.1 Process description	9
2.2 Material, energy and CO ₂ flows	11
3 Steel products and application	17
3.1 Products	17
4 Options for decarbonisation	19
4.1 Technology description	19
4.1.1 Top gas recycling blast furnace (TGR-BF)	20
4.1.2 HIsarna	22
4.1.3 ULCORED	23
4.1.4 ULCOWIN and ULCOLYSIS	25
4.1.5 Comparison of steelmaking technology progress	26
4.1.6 Use of biomass	26
4.1.7 CO ₂ capture and storage	28
4.1.8 CO ₂ capture and utilisation	33
4.1.9 Steel recycling	34
4.1.10 Energy efficiency	35
4.2 Material, energy and CO ₂ flows	35
4.3 Investment and operating costs	47
5 Discussion	52
5.1 Current steelmaking process	52
5.2 Decarbonisation options	52
References	56
Appendix A – current steelmaking process calculations	61
A1. Material and energy calculations for current steel production process	61
A2. CO ₂ emission data for current steel production process	65

FINDINGS

Summary

- Tata Steel in IJmuiden (TSIJ) is currently the only primary steel producer in the Netherlands, with a crude steel output of approximately 7 Mt in 2017. The current production process is based on the blast furnace route, with coal as the primary energy source. This technology route has been used since the birth of the site in 1918.
- Significant technological improvements have been made on this technology making Tata Steel IJmuiden one of the most efficient steel producers in the world with blast furnace technology.
- To meet the climate agreement goals for 2030 and 2050, TSIJ is required to change its production process to significantly reduce CO₂ emissions, potentially requiring more substantial investments than ever before.
- A demonstration plant of one decarbonisation option, called HIsarna, is operating at IJmuiden. The scale-up on this plant is planned by Tata Steel in Jamshedpur, India.
- There are four primary technological options for steel production to decarbonise, as defined by the Ultra-low CO₂ Steelmaking program (ULCOS): smelting reduction process (HIsarna) with CCS, top gas recycling blast furnace (TGR-BF) with CCS, direct iron reduction (by natural gas with CCS or hydrogen) and iron ore electrolysis (ULCOWIN, ULCOLYSIS). Several of these options, as well as the current blast furnace process, have the potential to implement biomass as both a feedstock and a fuel. This could significantly lower the overall CO₂ emissions emitted depending on the extent of implementation.
- The energy requirements of the abovementioned decarbonisation options differ both by energy source and quantity. TGR-BF and HIsarna options are primarily based on coal, direct reduction is primarily based on either natural gas or electricity (for hydrogen production) and ULCOWIN/ULCOLYSIS are primarily based on electricity. Thus, the cost of energy and infrastructure requirements differ greatly for each option. However, energy costs estimates are out of the scope of this report.
- The overnight capital investment cost of each decarbonisation option differs greatly between options. An estimation of overnight capital costs for decarbonisation options comes with a great deal of uncertainty, especially for those options that have not been implemented on an industrial scale yet.
- Investment decisions are not solely based on energy prices and overnight capital investment costs of the steelmaking technology, there are many other relevant considerations. These include government regulations, site independence, public acceptance and resource availability.

FULL RESULTS

Introduction

This study begins by describing the current, and only, primary steel production facility in the Netherlands with an overview of the process material and energy flows, and how by-products are utilised both within and outside the site. Subsequently, the technological options of decarbonisation are investigated with potential savings of material and energy, emission reductions, investment costs and infrastructure requirements. The study is part of the MIDDEN project (Manufacturing Industry Decarbonisation Data Exchange Network). The MIDDEN project aims to support industry, policymakers, analysts, and the energy sector in their common efforts to achieve deep decarbonisation. The MIDDEN project will update and elaborate further on options in the future, in close connection with the industry.

Scope

In the Netherlands, steel producers include: Tata Steel IJmuiden, North Holland. Production processes include blast furnace process, basic oxygen furnace process, coking, sintering, pelletizing, gas-fired electricity and heat generation, oxygen production and downstream steelmaking processes¹; products include: crude steel. The main options for decarbonisation are smelting reduction process (HIsarna) with CCS, top gas recycling blast furnace (TGR-BF) with CCS, direct iron reduction by natural gas with CCS (NG-DR with CCS) or hydrogen (H-DR), iron ore electrolysis (ULCOWIN, ULCOLYSIS).

Reading guide

Section 1 describes the current steel production status at Tata Steel IJmuiden, beginning with an historical overview leading to current steel production levels and environmental impacts to provide basic context for the rest of the report. Section 2 provides a description of the current primary steel production process at Tata Steel with material, energy and CO₂ flows and how the plant operates logistically for material pre-processing and with third parties on site to utilise by-products. In section 3 the crude steel production volume and the main markets that it is processed further to supply to is described. Section 4 introduces the main decarbonisation options with an overview of the process, stage of development of such technologies, and their estimated material, energy and CO₂ emission flows. Section 5 discusses each technology's technical feasibility and resource requirements leading to conclusions regarding alternative pathways which Tata Steel can take in the coming decades to meet climate goals.

¹ Downstream steelmaking processes such as continuous casting are within the scope of the overall energy and CO₂ emissions of both the current production process and decarbonisation options. However, the decarbonisation options of the downstream steelmaking processes themselves are out of scope.

1 Current primary steel production

1.1 Steel industry in the Netherlands

Steel production in the Netherlands is dominated by primary steel production, the production of graded steel from iron ore. The only large-scale steel producer in the Netherlands is Tata Steel IJmuiden (TSIJ) which applies the blast furnace production process. Steel production at TSIJ primarily supplies customers in three markets: packaging, construction and the automotive industry (Tata Steel Europe, 2018).

1.2 Company overview

TSIJ is one of two integrated steel mills that make up Tata Steel Europe, a subdivision of the Tata Steel Group, one of the largest steel groups in the world. The other primary steel production mill of Tata Steel Europe is based in Port Talbot, UK. There are several downstream processing plants throughout Europe (Tata Steel Europe, 2018), however these are out of the scope of this report. In 1918 the first steel company was established in IJmuiden, at the same location as today, now covering 7.5 km² on the North Sea coast. The steel mill has undergone several company transitions in the past two decades. In 1999 Corus Group was formed following a merger between British Steel and Koninklijke Hoogovens before becoming part of Tata Steel Europe in 2007. Currently, there are more than 9,000 employees based in IJmuiden. TSIJ recorded an annual net turnover of EUR 3.6 billion in 2017. In the same year, a net profit after taxation of EUR 235 million was achieved, an EUR 76 million increase from the previous financial year (Tata Steel, 2017).

1.3 Production overview

TSIJ currently produces just over 7 million tonnes of crude steel annually. Figure 1 displays the historic crude steel production from 2008, showing that production level has remained relatively stable over the past decade (World Steel Association, 2018).

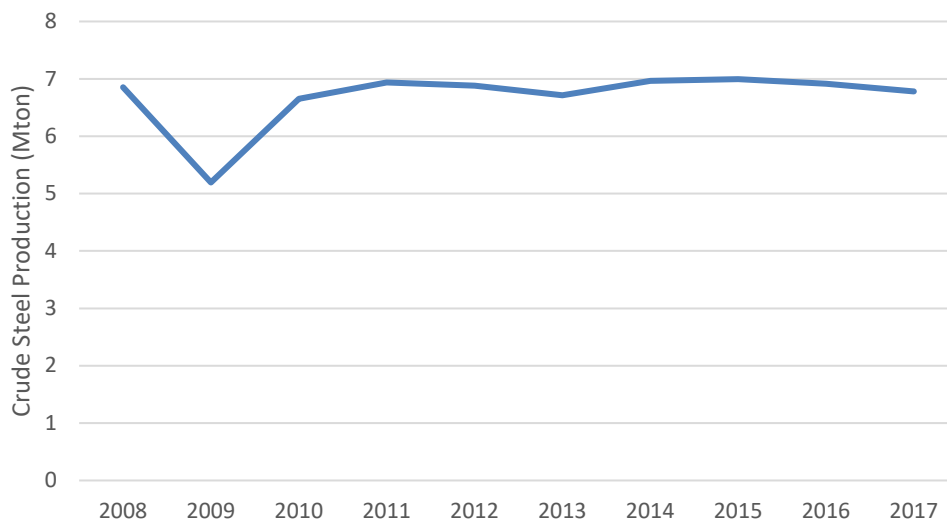

Figure 1. Crude steel production in the Netherlands 2008 – 2017

The main processing units on-site within the scope of this report are:

- 2 coke plants
- 1 pelletizing plant
- 1 sinter plant
- 2 blast furnaces
- 1 basic oxygen furnace plant
- 1 oxygen production plant (3rd party owned)
- 3 power generation plants (3rd party owned).

The site layout of the abovementioned processing units, alongside units outside of the scope, is illustrated in Figure 2 (Tata Steel Europe, 2016).

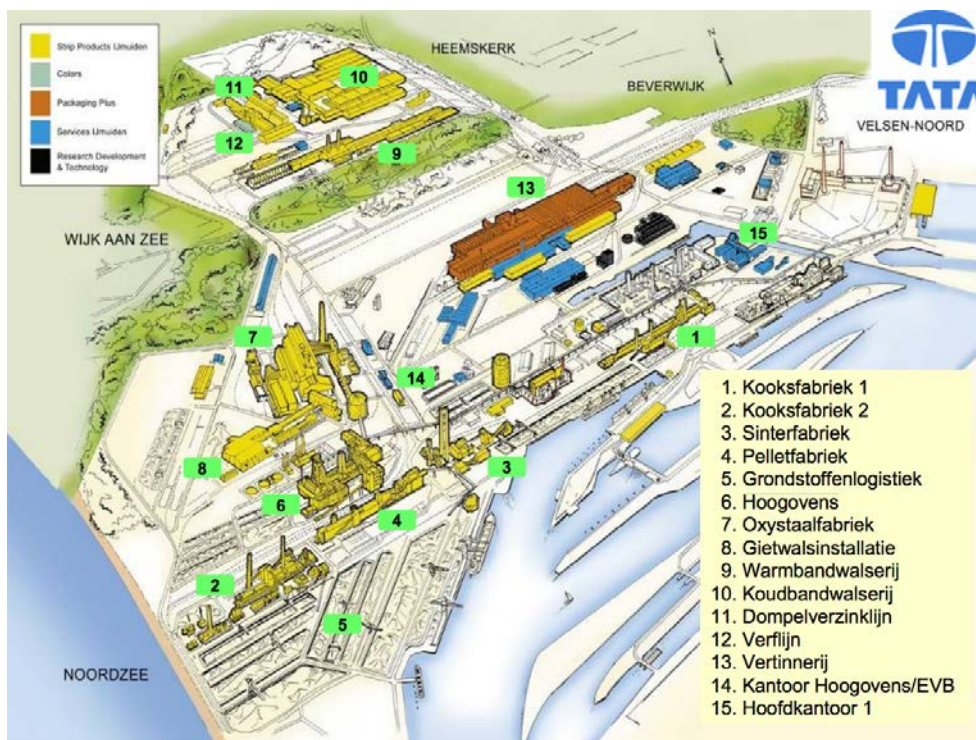

Figure 2. Site layout overview at Tata Steel IJmuiden (Tata Steel Europe, 2016)

Steel production is one of the most energy intensive industries in the Netherlands primarily due to the high energy requirement of the two blast furnace plants. The high energy requirement in the blast furnaces is mainly owed to the primary reaction in the vessel in which iron ore is reduced to pure iron. Electricity plays a significantly smaller part of the overall energy demand in the production process at TSIJ but still consumes 3% of the total electricity consumption in the Netherlands. TSIJ generates its own electricity from process gas at several stages in the process which are distributed among four on-site power plants producing an equally significant amount of electricity (as well as heat). The utilisation of process gases to produce electricity and heat leads to approximately half of the CO₂ emissions being emitted by the gas-fired power plants and the other half being emitted directly from the steelmaking processes (Tata Steel, 2016).

The World Economic Forum awarded TSIJ into its prestigious community of 'Lighthouses', a distinction awarded to manufacturing facilities which are seen as technological leaders (Tata Steel, 2019). Table 1 displays a summary of the performance data at the IJmuiden site; including crude steel production, CO₂ emissions, water consumption and waste disposal and recycling (Tata Steel, 2016).

Table 1. Performance data of Tata Steel IJmuiden 2014-2016 (Tata Steel, 2016).

	Unit	2014	2015	2016
Crude steel production	Mt	6.866	6.922	6.849
CO ₂ emissions (scope 1) ²	Mt	5.93	6.29	6.30
CO ₂ emissions (scope 1,2,3) ^{3,4}	Mt	11.95	12.03	12.47
Fresh water consumption	m ³ /t steel	4.65	4.49	4.64
Waste generated	kt	228	321	212
Waste disposal to landfill	kt	43	57	40
Waste re-used, recycled	kt	176	254	164
Environmental complaints		1067	876	1161

² Scope 1 emissions are direct emissions from owned or controlled sources. Each scope definition is based on the GHG Protocol Corporate Standard (Greenhouse Gas Protocol, 2019).

³ Scope 2 emissions are indirect emissions from the generation of purchased energy (Greenhouse Gas Protocol, 2019). This includes the on-site residual gas power plants.

⁴ Scope 3 emissions are all indirect emissions (not included in scope 2) that occur in the value chain, including both upstream and downstream emissions (Greenhouse Gas Protocol, 2019).

2 Steel production processes

This section provides a description of each of the separate processes involved in steel production, with associated material, energy and CO₂ flows utilising data reported by both TSIJ and also relevant literature to provide good approximations. This forms a basis for the decarbonisation options to compare energy and CO₂ intensities as well as material requirements.

2.1 Process description

There are two main steel production routes used today: (i) blast furnace (BF) process and (ii) electric arc furnace (EAF) process. Globally the former accounts for approximately 70% of steel production. The latter, based on secondary materials such as steel scrap, accounts for 30% (World Steel Association, 2018). TSIJ produces steel via the BF process. Iron ore and coal are the main raw materials, the majority of which are further processed into sinter and pellets (iron ore) and coke (coal) before entering the BF. Pig iron is tapped from the BF and is further processed into crude steel via the basic oxygen furnace (BOF) process in which the carbon content is lowered by oxygen blowing. The BOF typically facilitates 16% of scrap steel to increase recycling rates. The level of scrap steel varies with time depending on price and availability of scrap of sufficiently good quality. The crude steel product leaving the BOF is then processed further into rolls and sheets and can be finished by galvanisation, tin plating or lacquering if required. However, the processing stages after the crude steel product are outside of the scope of this report. Presented below are basic descriptions of the main processes in the BF processes route (Daniels, 2002) (EIPPCB, 2013) (Gielen & Van Dril, 1997).

Coke production

Coke (and coke breeze) is a carbon-containing solid material produced in a coke oven by batch pyrolysis of coking coal. The reaction takes place at temperatures above 1000 °C and each batch lasts approximately 16-20 hours. The coke is then cooled by the addition of water before it can be utilised. The main by-product of this process is coke oven gas (COG), which has a typical volumetric composition of H₂ = 57.3%, CH₄ = 23.7%, CO = 6.6%, CO₂ = 2.6%, N₂ = 7.2% and other hydrocarbons = 2.4% (Bieda, Grzesik, Sala, & Gawel, 2015). Part of the COG is recycled and combusted to provide heat to the oven, whilst the remainder of the COG is combusted to heat the BF, for electrical power generation and in the downstream steelmaking processes. Raw COG contains valuable by-products including tar, sulphur components, ammonia and light oil (BTX) that are further processed and sold. TSIJ has two coking plants with a coke oven firing system and a process gas treatment unit to recover the emitted COG. The overall thermal efficiency of the coke oven system is approximately 80%. The coking plant is one of the most energy intensive parts of the steelmaking process, as well as one of the costliest. Hence, TSIJ is continually trying to increase the direct intake of pulverized coal into the BF to reduce the coke requirements. Currently, TSIJ produces more coke than it requires, with the excess being sold to third-parties.

Sinter and pellet production

Iron ore occurs naturally as lump ore and fine ore. BFs are not capable of solely using fine ore as the feedstock and so agglomeration of fine ore is necessary. Lump ore may be possible to use solely, however is scarcer and more expensive than producing sinter and pellets from fine ore. The sintering process consists of heating up fine ore, alongside additives such as limestone, causing it to agglomerate into larger aggregates with a porous structure. A porous structure is important as the blast furnace is a counter-flow reactor and so gases must be able to pass through the iron ore material. In the pelletising process, the fine ore is mixed with additives, such as limestone and olivine, in a wet condition and pellets are formed with a binder and subsequently baked. Sinter and pellets are used in the BF, alongside a small proportion of lump ore in some modern BFs, such as at TSIJ.

Blast furnace

A BF is used to reduce (remove oxygen) iron ore to produce a hot liquid pig iron with a carbon content of 4% (Abspoel, 2018). Coke, sinter and pellets are the primary components fed into the top of the furnace and hot oxygen enriched air and pulverised coal are blasted from the bottom through the porous structures (tuyeres). This process results in partial combustion of the carbon from coke and coal, producing reducing gases (containing carbon monoxide) that heat the furnace resulting in liquid pig iron which is subsequently tapped off at the bottom and transported to the BOF. The ideal chemical equation of such reducing reaction from haematite (one of the most commonly used iron ore) is as follows (Gielen & Van Dril, 1997):

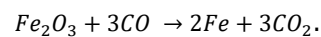

Slag is also produced as a by-product and tapped off separately at the bottom of the furnace to be sold on to other industries such as cement and asphalt. Excess reducing gases are used for power generation and recycled for heat generation or for other processes. A basic schematic of the input and output material flows are displayed in Figure 3 (Gao, Ge, & Jian, 2014).

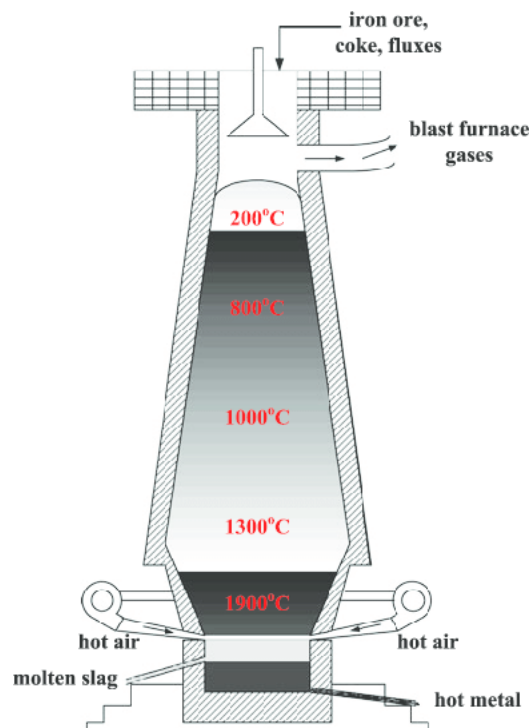

Figure 3. Schematic diagram of the blast furnace process

Basic oxygen furnace

The primary reaction in the BOF is the oxidation of carbon in the pig iron by the injection of oxygen. The degree of oxidation of carbon is varied depending on the desired steel product specification. The overall process is exothermal and hence the excess energy allows the possibility of increased levels of scrap steel to be added in the furnace. Scrap steel is also commonly inputted alongside pig iron in the BOF with the purpose of temperature control and to reduce the amount of pig iron required to produce crude steel. Slag is produced as a by-product from the oxidation of impurities such as silicon, manganese, phosphorus and sulphur.

Oxygen production

Oxygen is produced from air by a cryogenic separation unit owned and operated by Linde. Oxygen is required in both the BF and BOF, but at slightly different purities. The BF typically requires an oxygen purity of greater than 95vol% primarily for oxygen enrichment of the hot air blast. The BOF requires an oxygen purity of greater than 99.5vol% for the main process of blowing into the furnace. A higher nitrogen content may adversely affect the steel quality.

2.2 Material, energy and CO₂ flows

To gain a good understanding of the current steelmaking process, material and energy flows are calculated to match the current situation as closely as possible. This has been achieved by a combination of data provided by TSIJ and publicly available data. Material, energy and CO₂ flows differ somewhat each year. The presence of multiple sources to formulate these flows have left some ambiguity due to different reporting years. Thus, an attempt has been made to scale energy quantities to match totals reported for 2017, as reported by CBS (2017).

Figure 4 and Figure 5 display an overview of the material and energy flows respectively throughout the entire steelmaking process, including the work arising gases (WAGs) based power generation units. The figure identifies the source from which the value has been derived. Streams that required assumptions to balance the material and energy flows are detailed in Appendix A.

Power generation from WAGs is a significant part of the steelmaking processes in terms of electricity generation and subsequent CO₂ emissions. There are four main power generation units at TSIJ: Velsen 24, Velsen 25, IJmond 1 (owned and operated by Vattenfall) and a TSIJ-owned CHP plant known as *Energiebedrijf Tata* for the purpose of this report. Table 2 states the basic characteristics and a short explanation of these power generation units.

Steam generation and utilisation is difficult to determine and thus ranges based on EIPPCB (2013) are used. An exception is the output of the coke plant in which an assumption has been made that coke dry quenching (with heat recovery in the form of steam) is applied and hence a single value is given.

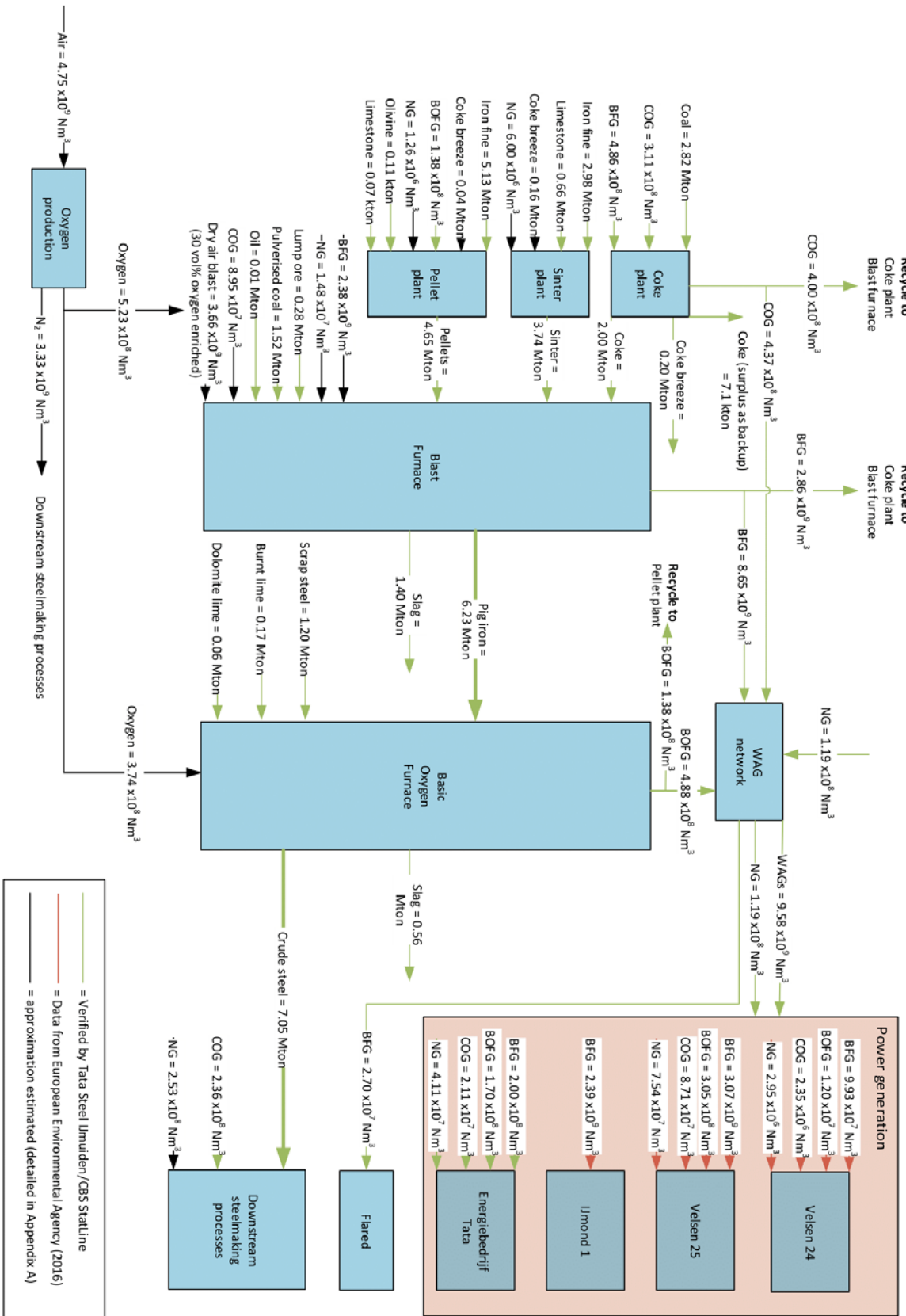

Figure 4. Annual material flow overview of the steelmaking process.

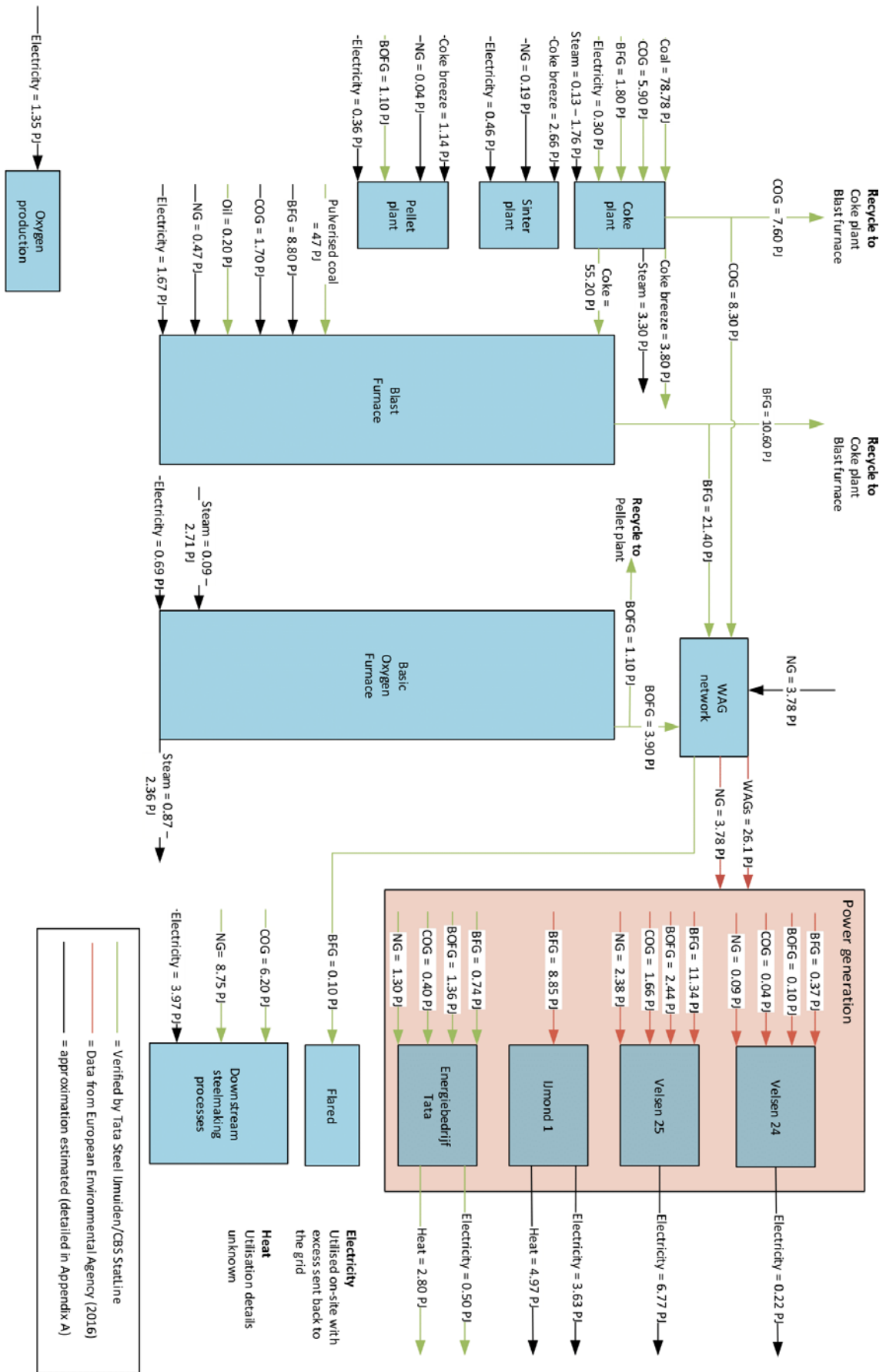

Figure 5. Annual energy flow overview of the steelmaking process

Table 2. Description of power generation plants

Name	Technology	Electricity capacity (MW _{el})	Heat capacity (MW _{th})	Main fuel	Other fuel(s)	Description
Velsen 24	CCGT	460	-	BFG	BOFG, COG, Natural gas	Serves as a backup unit when the other units are out of operation or when demand of electricity is greater (Vattenfall, 2019).
Velsen 25	CCGT	375	-	BFG	BOFG, COG, Natural gas	Base load unit that can run entirely on BFG, however natural gas is sometimes added to balance fluctuation in BFG supply (Vattenfall, 2019).
IJmond 1	CHP	144	105	BFG	-	Base load unit that can run entirely on BFG and produces both electricity and heat (Vattenfall, 2019).
Energiebedrijf Tata	CHP	17 ⁵	97 ⁶	-	BFG, BOFG, COG, natural gas	Operated by TSIJ with a mixture of WAGs and natural gas inputted.

Figure 6 displays the total final energy consumption of the main steelmaking processes, excluding the power generation units. The blast furnace is the most energy intensive process, due to the large input of both coke and pulverized coal. The coke plant is the second-most energy intensive process with a large input of coking coal to be processed into C for the blast furnace.

⁵ 0.5 PJ of electricity is reported to be generated annually and 8000 running hours are assumed to calculate the capacity (CBS, 2017).

⁶ 2.8 PJ heat is reported to be generated annually and 8000 running hours are assumed to calculate the capacity (CBS, 2017).

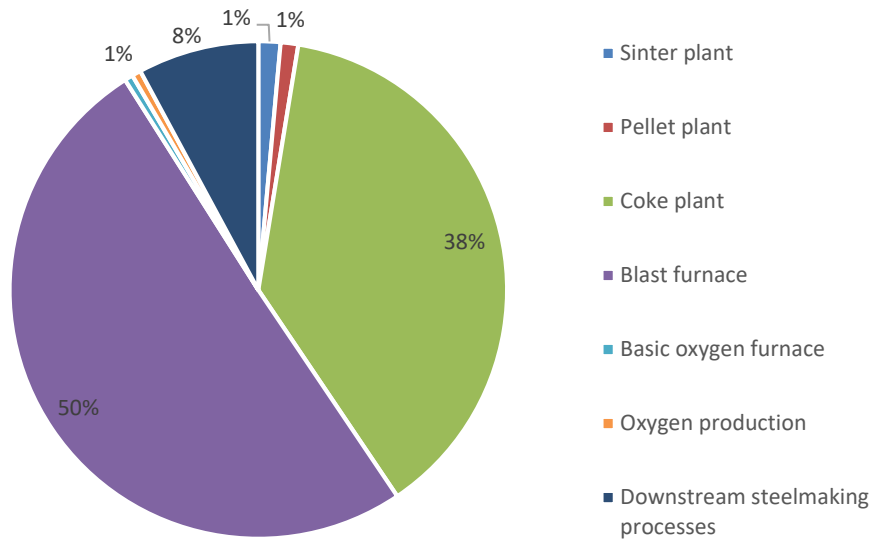

Figure 6. Total energy consumption distribution in steelmaking process

The main underlying interest in this report concerns the resulting CO₂ emissions of the process and how they are distributed within the process itself. To calculate this, a combination of CO₂ emission factors and carbon content of materials and fuels are used. Appendix A states the assumed CO₂ emission factors and carbon content of all materials and fuels in the process. Presented below is the methodology used for calculating the CO₂ emissions per process with a non-specific example (Figure 7). A true calculation is not given for conciseness of this report.

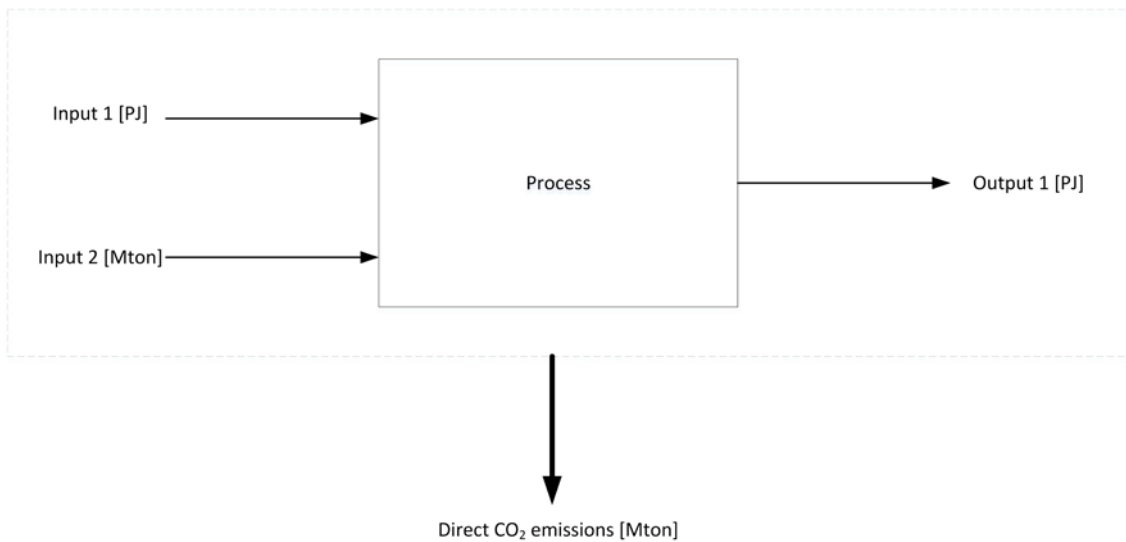

Figure 7. Schematic of CO₂ emission calculation example

$$(total\ CO_2 - input\ [Mton]) - (total\ CO_2 - output\ [Mton]) = direct\ CO_2\ emissions\ from\ process\ 1\ [Mton]$$

$$\left(\frac{input\ 1\ [PJ] \times input\ 1\ emission\ factor\ \left[\frac{kgCO_2}{GJ} \right]}{1000} + input\ 2\ [Mton] \times input\ 2\ carbon\ content\ [-] \times \frac{molecular\ mass\ CO_2\ \left[\frac{g}{mol} \right]}{molecular\ mass\ c\ \left[\frac{g}{mol} \right]} \right) M - \left(\frac{output\ 1\ [PJ] \times output\ 1\ emission\ factor\ \left[\frac{kgCO_2}{GJ} \right]}{1000} \right) = direct\ CO_2\ emissions\ [Mton]$$

Figure 8 displays the calculated direct CO₂ emissions per process, the emission distribution between processes and the specific emissions per tonne of crude steel. The total direct CO₂ emissions and specific direct CO₂ emissions are compared to the reported value from TSIJ in 2017 (Dutch Emissions Authority, 2019). The calculated values are slightly less than what is reported but are broadly similar, with differences likely arising from different values assumed for CO₂ emission factors and carbon content of materials.

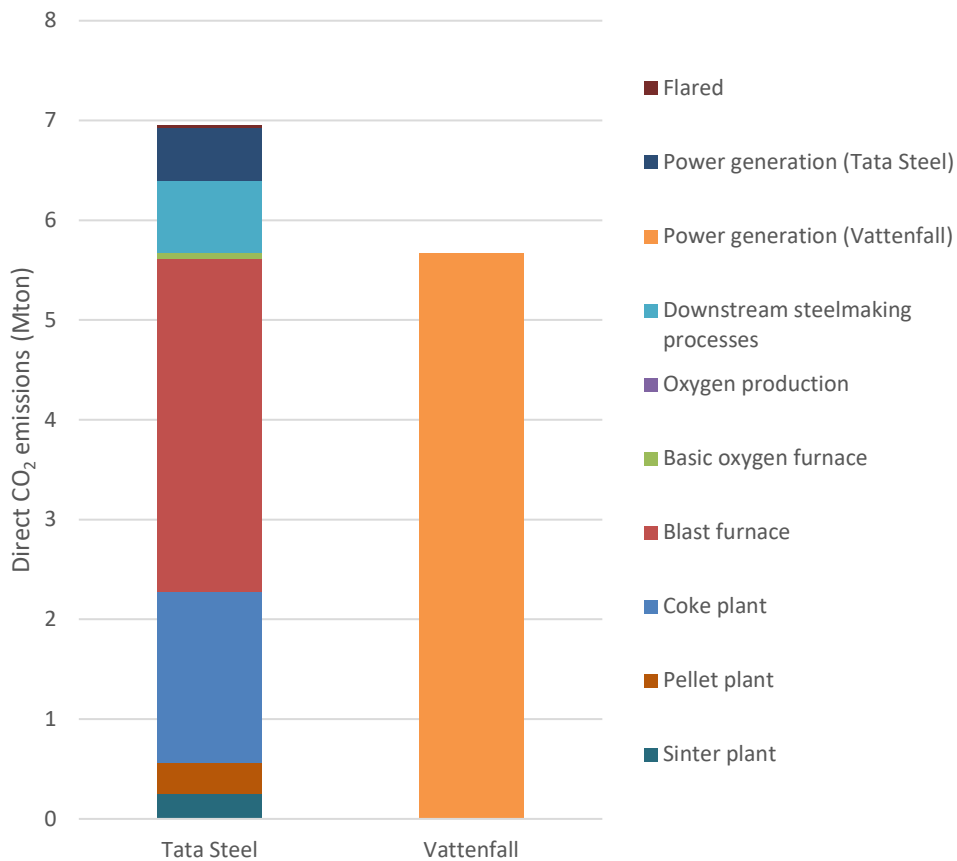

Figure 8. Calculated annual direct CO₂ emission distribution of steelmaking units and power generation plants

3 Steel products and application

Steel is an essential product for a wide range of applications such as buildings, cars and kitchen appliances. Steel produced in the Netherlands is consumed both within the Netherlands and exported. Demand for steel is strongly correlated with population and the stage of economic development of a country. The projection of EU steel demand conducted by Krishnan (2017) predicts that demand will decline from 161 Mt in 2016 to 130 Mt in 2050. This would suggest that in the Netherlands, production is unlikely to increase or decrease dramatically within this period.

This chapter presents an overview of the product range produced by Tata Steel in Europe. Future steel demand and the markets in which steel operates in are important when evaluating low-carbon steelmaking technologies. Not all required steel production levels and quality can be met by all steelmaking technologies in the coming decades. For example, some of the high grade steels that TSIJ currently produce cannot be made by using only scrap steel.

3.1 Products

The primary markets that Tata Steel in Europe operate in are engineering, automotive, packaging and construction. Within each of these markets, Tata Steel produce a wide range of industry specific products as well as generic products. The main products in these markets are listed in Table 3. A breakdown of sales by market sector and by product for Tata Steel Europe is illustrated in Figure 9 and Figure 10 (Tata Steel, 2019). Primary steel production by Tata Steel Europe takes place in the Netherlands and UK and this steel is exported to a range of downstream manufacturing operations throughout Europe. Hence, is it difficult to identify the product range solely from Dutch produced steel. The properties and specifications of products is out of the scope of this report but is readily available in the Tata Steel Europe product and service catalogue (Tata Steel, 2018).

Table 3. Tata Steel Europe products and services

Engineering	Automotive	Packaging	Construction
▪ Hot-rolled	▪ Electrical steels	▪ Structural	▪ Tinplate
▪ Direct-rolled	▪ Hot-rolled	▪ Floor plate	▪ ECCS
▪ Cold-rolled	▪ Direct rolled	▪ Materials and finishes	▪ Protact
▪ Metallic coated	▪ Cold-rolled	▪ Metallic coated	▪ Blackplate
▪ Pre-finished steel	▪ Metallic coated	▪ Walls	
▪ Electro-plated steel	▪ Electro-plated steel	▪ Roofs	
▪ Electrical steels	▪ Tubes	▪ Renewables	
▪ Tubes	▪ Tailor Welded Blanks	▪ Tubes	
▪ Coretinium	▪ Aurora Online	▪ Other	
▪ Raw materials			

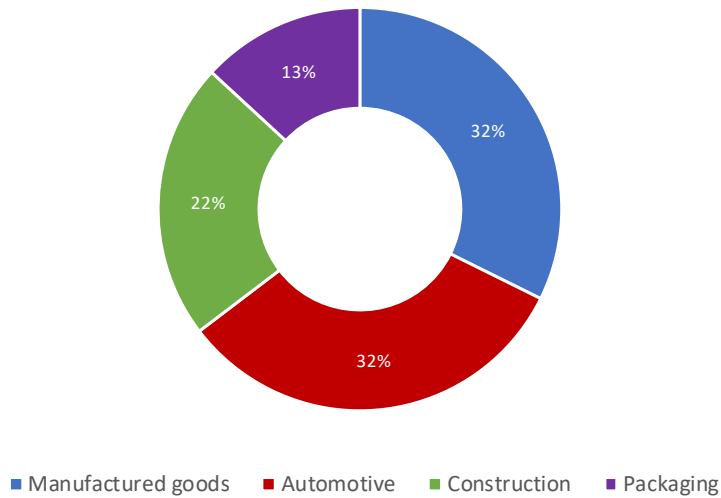

Figure 9. Tata Steel in Europe: sales by market sector (%sales volume)⁷

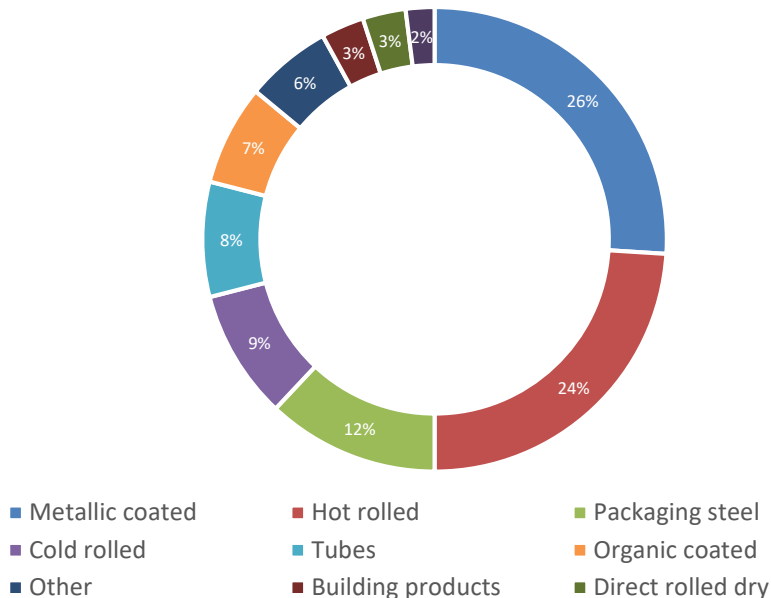

Figure 10. Tata Steel in Europe: sales by product (%sales volume)

⁷ Manufactured goods includes sales to Engineering, Lifting & Excavating, Independent Service Centres and semi-finished products.

4 Options for decarbonisation

This chapter presents the possible technology options that can apply to the Dutch steelmaking industry to significantly reduce CO₂ emissions. Firstly, a description of some of the possible technology options and the current status of implementation is given. Then, an estimation of the material and energy flows are described and presented schematically. Following this, a comparison is made between options based on energy requirements and CO₂ emissions emitted. Finally, a comparison is made between options based on estimations of the operating and overnight capital investment costs.

4.1 Technology description

There are a broad range of alternative technologies that have the potential to significantly reduce CO₂ emissions in steelmaking. Several different programmes have been established to develop these technologies, of which the main programmes are: ULCOS (EU), COURSE50 (Japan), POSCO (South Korea) and AISI (USA). From these programmes, ULCOS has the most extensive research scope (Junjie, 2018). The technologies being developed by these programmes all fall under the following categories and some examples are given:

- Revamped blast furnace: TGR-BF, IGAR
- Direct reduction ironmaking: ULCORED, MIDREX, HYL, HYBRIT, H2Future
- Smelting reduction ironmaking: HIsarna, COREX, FINEX
- Iron ore electrolysis: ULCOWIN, ULCOLYSIS, SIDERWIN
- Carbon capture and storage/utilisation.

For simplicity, and to avoid repetition of similar technologies, only some of the possible technologies are selected for further explanation and analysis. The ULCOS programme has identified the main options that it deems to have the most potential, covering all of the above mentioned categories: TGR-BF, ULCORED, HIsarna, ULCORED, ULCOWIN and ULCOYSIS. The ULCOS program has also identified a number of supporting technologies alongside these: hydrogen direct reduction steelmaking (H-DR), biomass-based steelmaking and carbon capture and storage (CCS). Due to these technologies covering the main alternative technology categories as well as having the most extensive research and available data, these technologies are selected for further consideration. However, this does not go to say that other technologies are not possible or relevant.

The Ultra-low CO₂ Steelmaking programme (ULCOS) was set up by the European Steel Technology Platform in 2004. The aim of the program was to develop new low-carbon steelmaking technologies that have the potential to reduce CO₂ emissions per tonne of steel by 50% from the 2004 best level of 2 tonnes of CO₂ per tonne of steel to 1 tonne of CO₂ per tonne of steel by 2050 (Junjie, 2018). The first phase (ULCOS I, 2004-2010) involved theoretical research and pilot-scale testing, costed EUR 3.5 million and received EUR 2 million in funding. The second phase (ULCOS II, 2010-present) takes four pilot technology projects that are deemed to have the greatest potential to develop further towards industrial scale (Abdul Quader M., Ahmed, Ariffin Raja Ghazilla, Ahmed, & Dahari, 2015).

Below, a description and the current implementation progress of the following selected alternative technologies are presented, with the option of supporting technology such as CCS, hydrogen and biomass for applicable options.

- TGR-BF
- HISARNA
- ULCORED
- ULCOWIN
- ULCOLYSIS.

4.1.1 Top gas recycling blast furnace (TGR-BF)

This technology involves modification of the existing BF to include top gas recycling. The reducing agents (CO and H₂) are recycled from the gas leaving the BF top after CO₂ removal. Recycling this stream reduces the demand for coke and hence reduces energy use and carbon emissions from the coking plant. TGR-BF primarily consists of the following modifications as compared to the conventional BF (van der Stel, et al., 2014):

- Injection of reducing top gas components CO and H₂ into the shaft and/or hearth tuyeres.
- Lower fossil-based carbon input due to lower coke rates.
- Use of pure oxygen in place of hot air blast at the hearth tuyere (elimination of nitrogen).
- Recovery of high-purity CO₂ from the top gas for underground storage.

Four versions of TGR-BF were originally tested. However, version 2 has been rejected due to a lower carbon saving than expected and challenging technology required to heat the recycle gas in two steps, by a recuperator and by partial oxidation.

The three remaining versions are described below and illustrated in Figure 11 (Abdul Quader M. , Ahmed, S, & Nukman, 2016). The versions differ mainly with regard to the level of preheating of the CO₂-free top gas and the location of the injection of the top gas in the blast furnace. Note: the top gas exits the furnace at a temperature of approximately 100 °C and the CO₂ removal is achieved by VPSA (Suopajärvi, 2014).

Version 1 – part of the CO₂-free top gas is recycled, preheated to 900 °C and injected into the BF through the tuyeres in the furnace stack. Another part of the CO₂-free cold top gas (25 °C), alongside oxygen and pulverized coal, are injected into the blast furnace through the tuyeres in the furnace hearth. The expected CO₂ saving from this version is 22% excluding CCS (Junjie, 2018).

Version 3 – the CO₂-free top gas is preheated to 1250 °C and injected into the BF through the tuyeres in the furnace hearth. The expected CO₂ saving from this version is 24% excluding CCS (Junjie, 2018).

Version 4 – part of the CO₂-free top gas is preheated to at 900 °C and injected into the BF through the tuyeres in furnace stack. Another part of the CO₂-free top gas is preheated to 1250 °C and , alongside oxygen and pulverized coal injected at into the blast furnace through the tuyeres in the furnace hearth. The expected CO₂ saving from this version is 26% excluding CCS (Junjie, 2018).

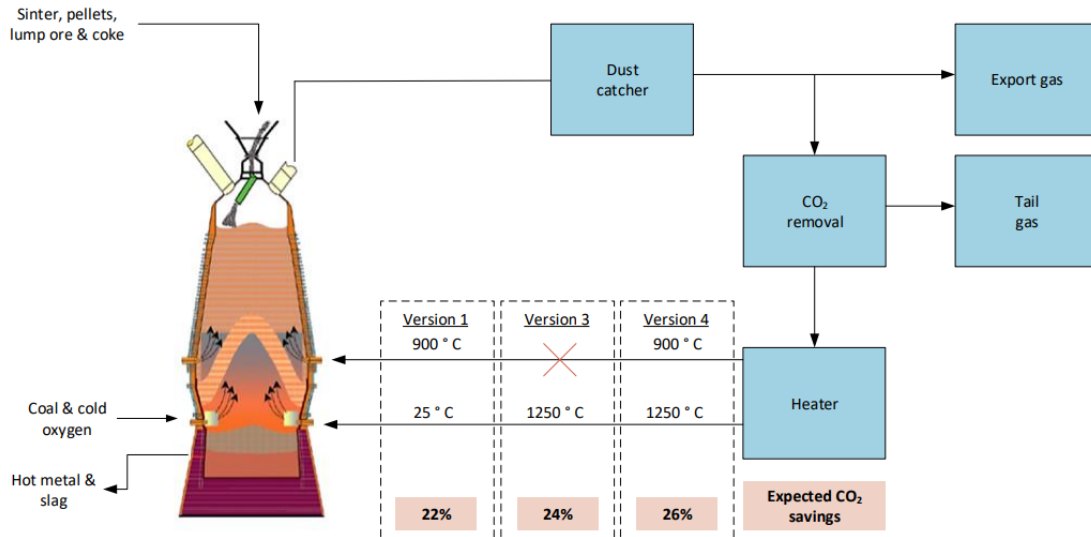

Figure 11. Simplified process flow diagram of considered variations of TGR-BF

The operation of the three versions have been tested in 2007 on an experimental BF (E-BF) in the facilities of LKAB, a Swedish iron ore manufacturer and supplier. Some additional technological additions were required to be implemented on the E-BF, this included a vacuum pressure swing adsorption (VPSA) device to remove the CO₂ from the top gas and vertical gas injection devices at the tuyeres of the furnace stack (Junjie, 2018).

The most notable results achieved during the tests at these facilities are as follows (Junjie, 2018):

- On average, for the three versions, the carbon input decreased from 470 kg/thm to 350 kg/thm (thm = tonne of hot metal).
- The top gas recovery rate of version 3 can reach 72%⁸, with carbon consumption reduced by 15%. The top gas recovery rate of version 4 can reach 90%, with carbon consumption reduced by 24%. As more CO and H₂ is injected, the reduction rate of iron ore increases and hence the consumption of coal and coke is reduced. The consumption of coal and coke is reduced at a rate of 17 kg for every additional cubic meter of CO and H₂.
- VPSA unit operated stably, processing 97% of the recycled top gas in the blast furnace. The injected gas contained, on average, 2.67vol% of CO₂ with a CO recovery rate of 88%, thus achieving the required composition and quantity for the process.
- In conjunction with CCS units, the quantity of CO₂ is proved to be able to be reduced by 1270 kg/thm with TGR-BF. This is 76% of the total CO₂ emissions in the ironmaking process. However, the version in which this result is achieved is not explicitly stated.

In conclusion, the test results validated the operation, safety, efficiency and stability of the TGR-BF. Version 4 proved to have the greatest emissions reduction potential and hence is the priority of the next round of testing with an industrial-scale BF. TGR-BF also has the potential to substitute coal with a source of biomass for further emission reduction, although tests have not been carried out for this.

⁸ Top gas recovery rate refers to the amount of top gas that is recycled back into the blast furnace rather than exported. The rate is likely determined by impurities in the stream making it less suitable for recycling.

4.1.2 HIsarna

A conventional BF requires the pre-processing of raw materials; iron ore into sinter and pellets and coal into coke. HIsarna is based on a smelting reduction process, eliminating the pre-processing steps by allowing the raw materials to be injected directly into a reactor as powders. Throughout the HIsarna reactor, the temperature is above the melting point of iron, allowing iron ore to instantly melt and subsequently converted into liquid iron. At the top of the reactor (CCF cyclone), the temperature is increased further by the addition of oxygen to react with carbon monoxide present. The cyclone part of the reactor creates a turbulent environment that allows greater contact time for the hot gas to enter at the top and partially reduce and melt the iron ore. The degree of partial reduction in the cyclone is typically in the range of 10-20% (Junjie, 2018).

The molten iron ore then falls to the bottom of the vessel (smelter) and comes into contact with powder coal which is injected at a high speed in the bottom after being decomposed and preheated in a coal decomposition furnace. The reaction of carbon from the powder coal with the melted iron ore creates liquid iron. The temperature in the smelter is around 1400-1450 °C with 4vol% dissolved carbon (Junjie, 2018).

The partly combusted gas leaving the smelter is then internally circulated to provide hot fuel gas to the cyclone. The pure liquid iron is then tapped off at the bottom for further processing (Tata Steel, 2018). A simplified schematic of this process is displayed in Figure 12 (Junjie, 2018).

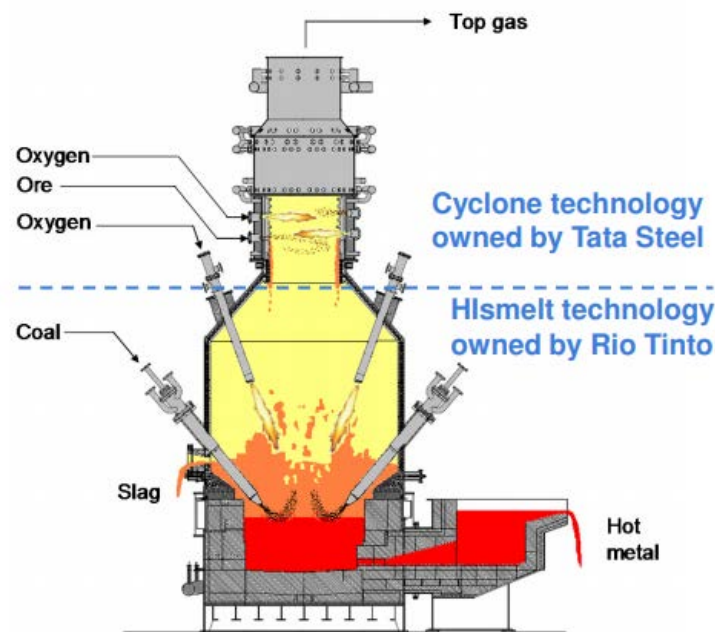

Figure 12. Simplified schematic of the HIsarna process with CCS

If implemented on an industrial scale, HIsarna is claimed to produce at least 20% lower CO₂ emissions and use at least 20% less energy compared to conventional steelmaking process. It is also ideally suited for CCS due to the absence of nitrogen in the gases, the compressibility of the gas due to sufficient CO₂ content and the once-through gas flow nature. Taking into account CCS, up to 80% CO₂ reduction can be achieved compared to the conventional steelmaking process (Tata Steel, 2018). Besides from energy and carbon savings, and hence cost reduction, HIsarna can eliminate 90% of the process phosphorous to slag. This allows

the use of cheaper, high-phosphorous iron ore which would not normally be accepted in the conventional process.

A HIsarna pilot plant has been successfully designed and developed at TSIJ since 2011. The project has been jointly developed by Tata Steel and the mining company Rio Tinto. Further testing and development is being undertaken alongside additional partners: ArcelorMittal, ThyssenKrupp, Voestalpine and technology supplier Paul Wurth. In addition to the partner companies, the European Union has provided significant funding for the plant and in October 2017, a six-month test campaign was carried out proving that liquid steel can be produced for high running hours. It is estimated that this campaign costed approximately EUR 25 million. Following the success of this campaign, the next stage is intended to design, construct and test a larger-scale pilot plant with an estimated investment of EUR 300 million. It is anticipated that this will have to go through several years of testing 2 to 3 times the size of the current pilot plant at IJmuiden with a production capacity up to 10 times greater (Tata Steel, 2018). In November 2018, it was announced that the new large-scale pilot plant will be built in Jamshedpur, India. The plant is planned to initially produce 400,000 thm/year with a scale up to 1 million thm/year eventually. The new plant does not signal the closure of the current pilot plant at IJmuiden, which is currently producing 60,000 thm/year (Process Control, 2018). An illustration of the HIsarna pilot plant layout at TSIJ is shown in Figure 13 (Tata Steel, 2018).

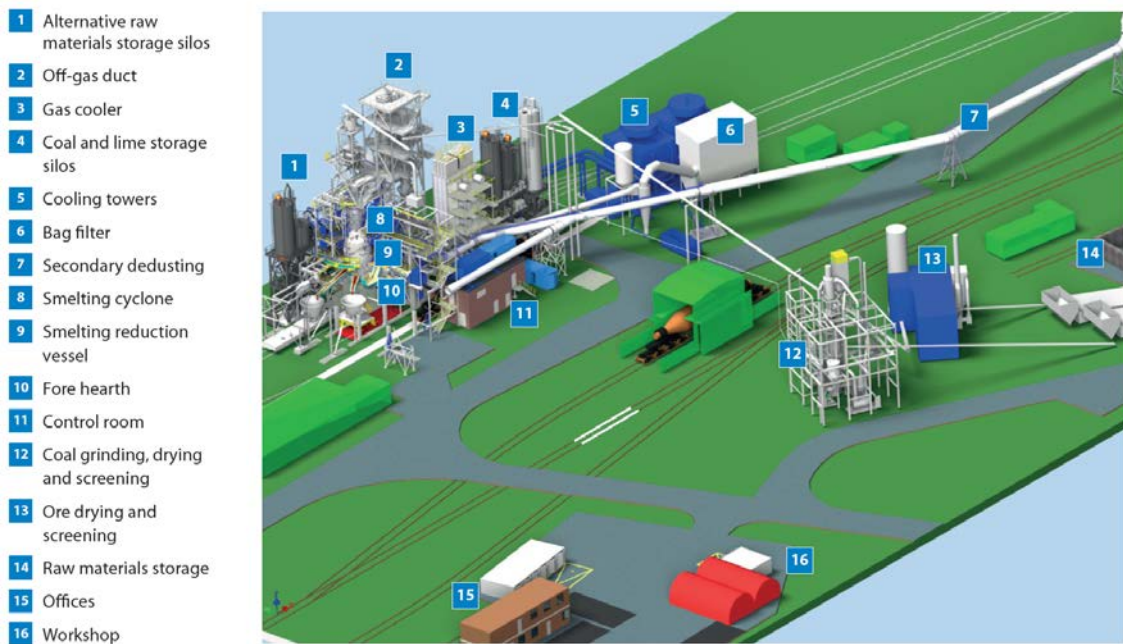

Figure 13. Layout of HIsarna pilot plant at TSIJ

4.1.3 ULCORED

ULCORED is a direct reduction technology that produces direct-reduced iron (DRI) in a shaft furnace. The main features of ULCORED compared to other direct reduction-based technologies are as follows:

- The use of pure oxygen in the shaft furnace produces a flue gas with no or low nitrogen content, making CO₂ capture easier.
- Reduced natural gas requirements due to the recycle of the flue gas after CO₂ removal to act as a reducing agent.
- Possibility to use alternatives to natural gas: coal, biomass and hydrogen.

A schematic illustration of natural gas-based ULCORED is displayed in Figure 14 (Sikstrom, 2013). With hydrogen as the reducing agent, the only by-product in the shaft furnace is water. This means that zero CO₂ emissions are produced in the ironmaking stage, with the overall emissions being entirely associated with hydrogen-production, pellet plant, EAF and downstream steelmaking processes. The use of hydrogen in the ULCORED process is researched less than that of natural gas or coal and thus there is still a lack of knowledge on its potential. A schematic illustration of hydrogen direct reduction, not specific to ULCORED, is displayed in Figure 15 (Ahman, et al., 2018).

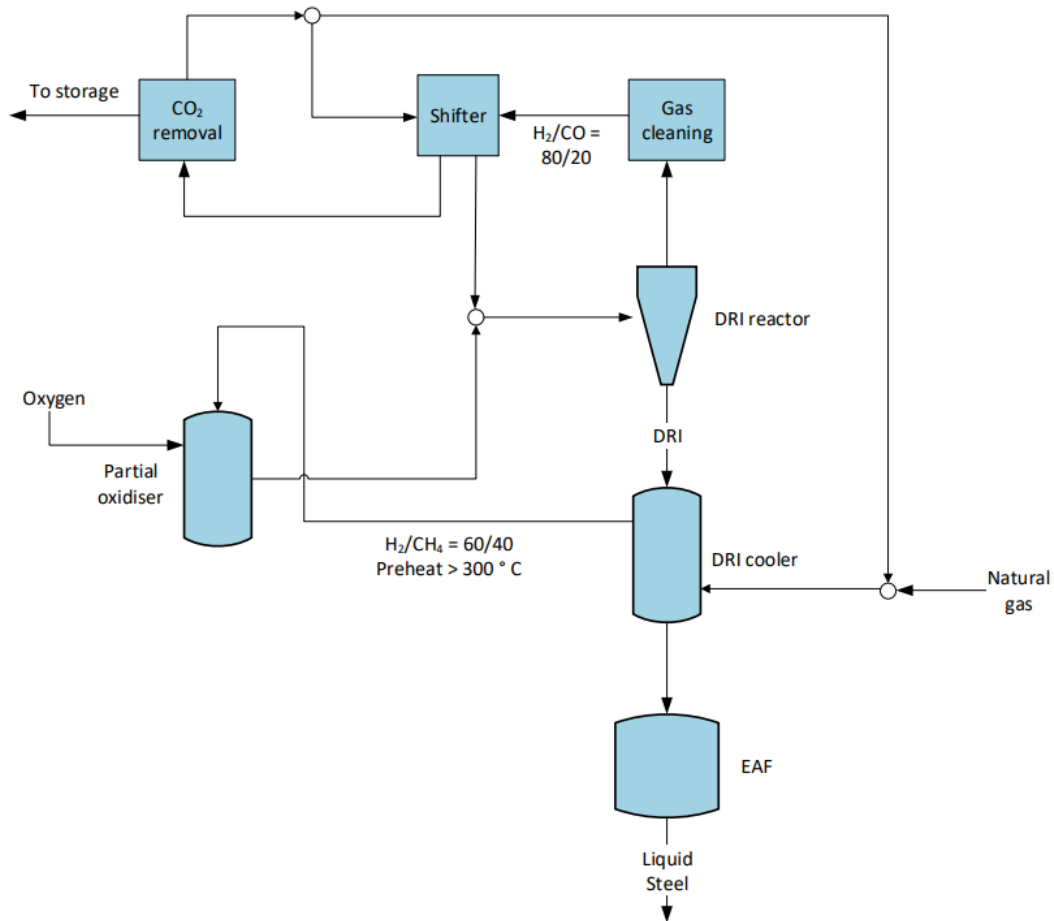

Figure 14. Basic schematic of natural gas-based ULCORED

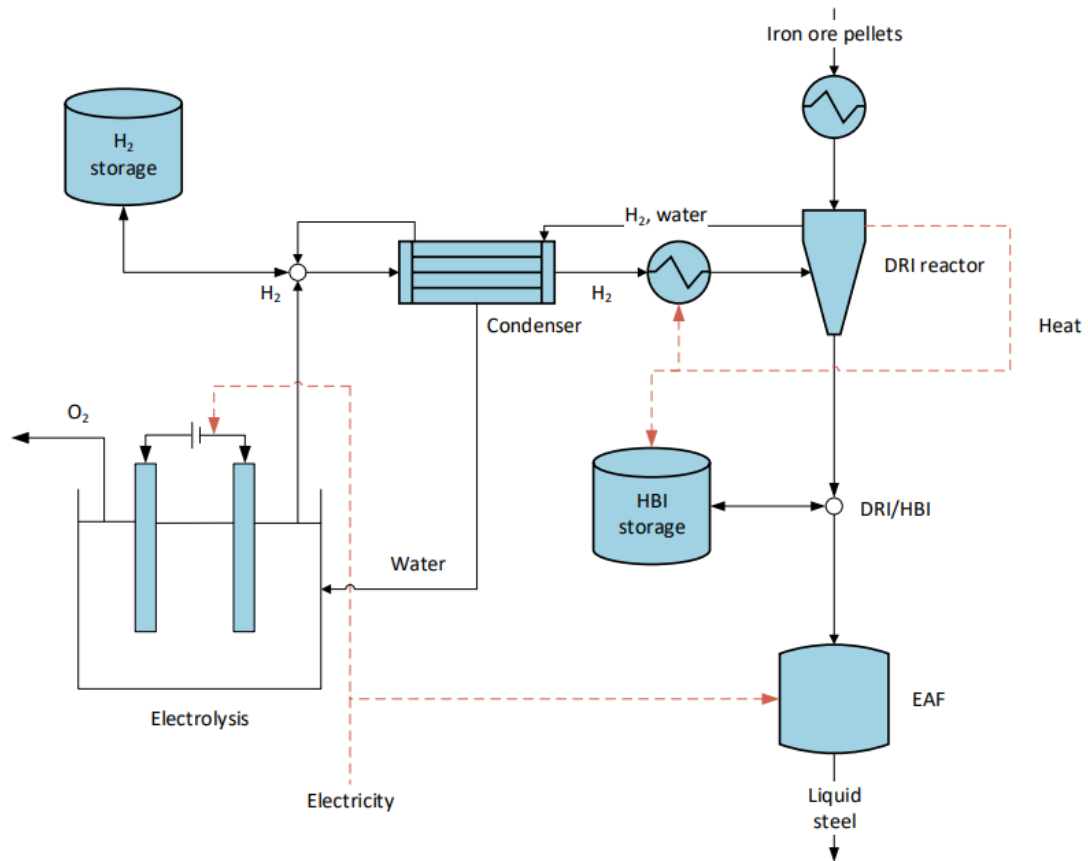

Figure 15. Example schematic of hydrogen-based direct reduction

4.1.4 ULCOWIN and ULCOLYSIS

Electrochemical reduction of iron oxide forms the basis of both ULCOWIN and ULCOLYSIS technologies. ULCOWIN utilises direct electrolysis powered by electricity to produce iron and oxygen from iron ore particles submerged in an alkaline electrolyte (NaOH) solution at a temperature of ~ 110 °C. A schematic of the basic working principle of the ULCOWIN process is displayed in Figure 16 (Moseley & Garche, 2014). This electrolysis technology is emission-free when powered by renewable electricity sources. The overall emissions are hence fully dictated by pre-treatment processes, EAF and downstream processes. During the ULCOS I phase, an iron purity of 99.98% was achieved with an energy consumption of 9.36 to 10.8 GJ per tonne of pure iron. However, the production rate was very low at around 5 kg pure iron per day.

One solution to overcome the production rate constraint, is to dissolve iron ore in a molten oxide solution at 1600 °C, higher than the melting point of iron, using electrical direct reduction. This technology is known as ULCOLYSIS. The (inert) anode is submerged in the electrolyte solution and electrical current is passed between this anode and a liquid iron pool connected to the circuit as the cathode. This produces oxygen gas at the anode and liquid iron at the cathode. Both technologies based on iron ore electrolysis are currently the least developed of the four ULCOS technologies. However, the electrolysis process itself is very mature with its wide implementation in smelting metal such as aluminium, zinc and nickel (Junjie, 2018) (Abdul Quader M. , Ahmed, Ariffin Raja Ghazilla, Ahmed, & Dahari, 2015).

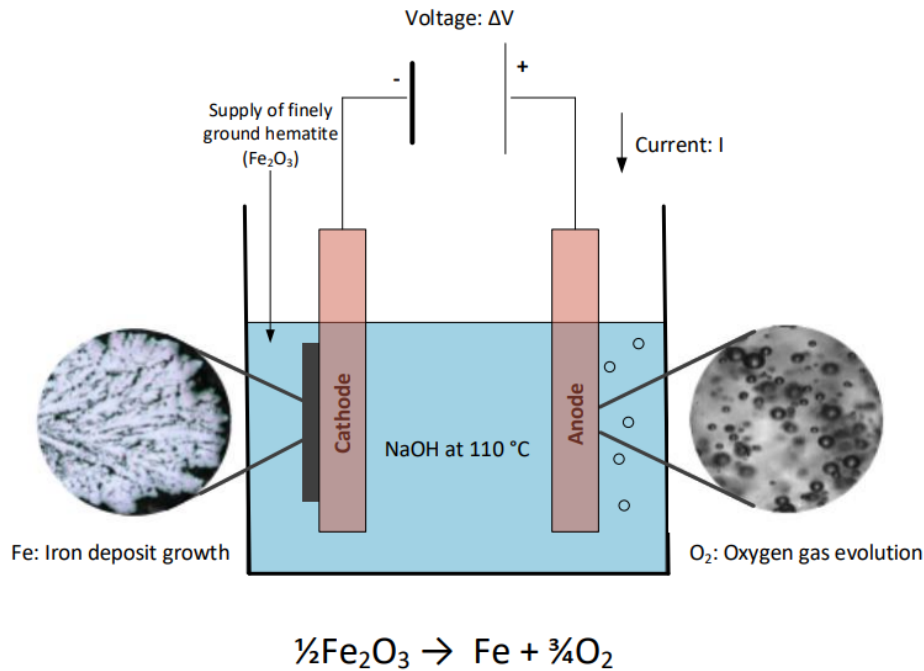

Figure 16. Basic schematic of iron ore electrolysis

4.1.5 Comparison of steelmaking technology progress

Table 4 displays a comparison of the TRL (technology readiness level) of decarbonisation options to give context to their possible deployment in the Netherlands (IEA, 2019) (ICF Consulting Services Limited and Fraunhofer ISI, 2019).

Table 4. Comparison of TRL of steelmaking decarbonisation options

Technology	TRL
TGR-BF	6 - 7
HIsarna	5
ULCORED (natural gas)	2-4
H-DR	7 ⁹
ULCOWIN/ULCOLYSIS	5-6 (ULOCWIN) <5 (ULCOLSYIS)

4.1.6 Use of biomass

Using biomass as a reducing agent has the potential to achieve zero and even negative net carbon emissions. This is possible because the carbon cycle is short, the CO₂ is recently extracted from the atmosphere by plants, as opposite to a very long time ago in the case of fossil fuels. Besides from this, the sulphur content in biomass is typically low, meaning that less capital is required for sulphur removal from iron. Although the use of biomass is much

⁹ This refers to more developed hydrogen-direct reduction technologies (e.g. HYBRIT), rather than hydrogen-based ULCORED.

less technologically complex than some of the other low-carbon technologies, it has several important conditions to fulfil: (i) the harvesting of biomass does not degrade its environmental conditions (such as soil, water, air and biodiversity) for future use. (ii) The use of biomass does not threaten food prices and the habitation of humans (Abdul Quader M., Ahmed, S, & Nukman, 2016).

Biomass-based steel production is already in practice on a small scale. Charcoal from eucalyptus trees in Brazil is being used in a small-scale BF as 100% of the feedstock. However, the use of eucalyptus trees in Europe is not realistic, but it does show the potential and thus research and development of other biomass sources which are more feasible in Europe is worth investigating.

Charcoal is cited as the most feasible biomass material for substitution and its possible fossil fuel substitution range are given in Norgate, Haque, Somerville, & Jahanshahi (2012). Tests on HIsarna are currently increasing charcoal substitution and a target of 40% charcoal substitution was made for 2017-18. Although this goal has not been seen to be proven yet, it is assumed technically possible for this report. An important consideration is that although it may be technically possible to substitute charcoal 100%, this may only be feasible at a small scale and not on an industrial scale. Unfeasibility of such high substitution may arise from lack of spatial requirements (lower energy density of some biomass sources) or the undesirable mechanical properties of the selected biomass material. For simplicity and lack of relevant literature on industrial scale applicability, the upper limits from Norgate, Haque, Somerville, & Jahanshahi (2012) are used. The possible charcoal substitution rates are summarised in Table 5. The possible substitution rate for ULCORED is not cited in literature and thus will not be included in further results to avoid making conclusions on uncertain data.

Table 5. Degree of implementation of charcoal per process for applicable steelmaking process plants

Steelmaking process plant	Fossil fuel substituted	Charcoal substitution rate (%)
Sinter plant	Coke breeze	50-100
Pellet plant	Croke breeze	50-100
Blast furnace	Pulverized coal	50-100
Blast furnace	Coke	2-10
HIsarna reactor	Coal	20-40 ¹⁰
ULCORED reactor	Coal or natural gas	n/a

¹⁰ The lower bound is estimated as half of the upper limit goal of 40% by TSIJ.

4.1.7 CO₂ capture and storage

The addition of carbon capture and storage (CCS) to the various decarbonisation options can reduce the CO₂ emissions significantly without any major changes in the steelmaking process. The high level of emission reduction is possible because of the presence of single fixed points where CO₂ is released and easily accessible. In some cases, the CO₂-containing flue gas has been purified from nitrogen, thus making the separation of CO₂ much easier. After separation, CO₂ must be compressed and in some cases cooled and then transported via pipelines or shipping/road vehicle tankers to an appropriate location for long-term storage (e.g. geological reservoirs in the deep ocean, or by the mineralisation of other compounds, chemical reactants or rocks) (Abdul Quader M. , Ahmed, S, & Nukman, 2016). TSIJ have initiated a CCS project called Athos which intends to conduct a feasibility study by 2022 and start storing CO₂ in 2027. It is initially estimated that the initial design will facilitate 5±1 MtCO₂/year to be stored in empty gas fields for at least 20 years (van Bracht & Braun, 2018).

CO₂ capture within the steelmaking industry, must be considered differently than to other sectors such as the power sector. Conventionally, CCS can be classified as pre-combustion, post-combustion or oxyfuel combustion. However, CCS in the steelmaking process does not always fall directly into one of these categories. CCS for steelmaking primarily concerns capturing emissions from the reduction of iron ore, rather than combustion or oxidation (Global CCS Institute, 2010). Ultimately, the most appropriate method of CCS is dependent upon the particular steelmaking technology used. The main CO₂ capture technologies being explored for steelmaking are discussed below.

Absorption

Absorption can be either physical or chemical and takes place in the bulk of the gas over two main stages. Firstly, a physical or chemical solvent is used to capture CO₂ in the first reactor (absorber) and then in the second reactor (stripper), the solvent is recovered, leaving a CO₂ pure stream. Chemical absorption processes are considered the most suitable for removing CO₂ from the BF steelmaking process, however, the process is expensive due to the large amount of thermal energy required to break the strong bonds formed between the solvent and CO₂. Amines, commonly monoethanolamine (MEA), are often used as the solvent in chemical absorption due to its good selectivity and capture efficiency properties. However, MEA has some drawbacks such as equipment corrosion, solvent degradation and low CO₂ loading capacity. Other chemical solvents being investigated include ammonia, which has shown to have a higher capture efficiency, higher loading capacity, lower costs and lower energy requirements compared to MEA. Despite these benefits, its high volatility and ability to easily form precipitates cause it to be easily lost in the process and thus this challenge is yet to be overcome (Abdul Quader M. , Ahmed, Ariffin Raja Ghazilla, Ahmed, & Dahari, 2015). Figure 17 illustrates the basic principles of the chemical absorption process (Abdul Quader M. , Ahmed, Ariffin Raja Ghazilla, Ahmed, & Dahari, 2015).

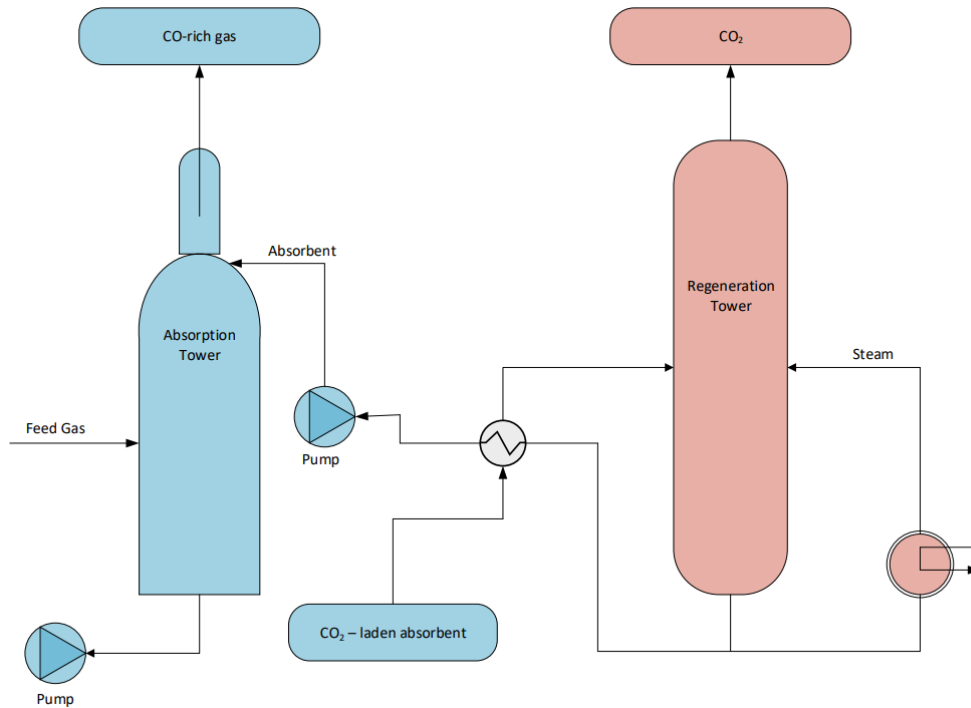

Figure 17. Schematic of chemical absorption-based CCS

Adsorption

Adsorption can occur by physical (physisorption) or chemical (chemisorption) bonding. Besides from the type of bonding, the different sorption technologies differ primarily by the nature of the CO₂-absorbing material (such as zeolite or activated carbon) and on the process of absorption and desorption on the respective material (changes in temperature or pressure) (Global CCS Institute, 2010). The main commercially available CCS adsorption technologies in the steelmaking industry are Pressure Swing Adsorption (PSA) and Vacuum Pressure Swing Adsorption (VPSA) (Abdul Quader M. , Ahmed, Ariffin Raja Ghazilla, Ahmed, & Dahari, 2015). These technologies separate CO₂ by loading the gas into the adsorption vessel under pressure and then separating it by swinging the pressure to atmospheric or a vacuum, respectively. One of the most promising PSA technologies for the steel sector is Sorption Enhanced Water-Gas Shift technology (SEWGS). This operates at high temperature, is claimed to achieve 90% CO₂ removal and has a SPECCA¹¹ of 1.95 MJ/tCO₂. A basic schematic of the physisorption is displayed in Figure 18 (Abdul Quader M. , Ahmed, Ariffin Raja Ghazilla, Ahmed, & Dahari, 2015).

¹¹ SPECCA stands for Specific Primary Energy per CO₂ Avoided.

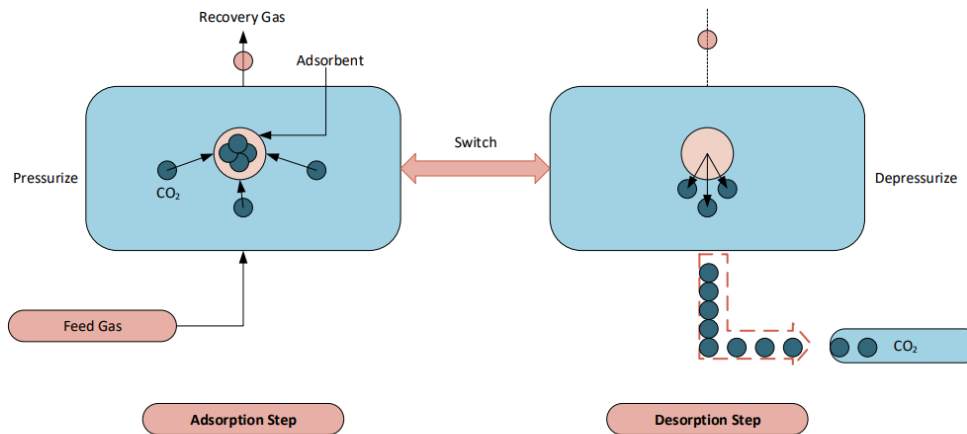

Figure 18. Basic process flow diagram of the physical adsorption-based CCS

Cryogenic

Cryogenic CO₂ separation is a distillation process for gaseous mixtures, analogous to a conventional distillation process for liquids. It involves cooling down the feed gas to sublimation temperatures in the range -100 to -135 °C (avoiding condensation) and using high pressures in the range 100 to 200 atm to separate out CO₂ based on the differences in boiling points of the gaseous components. The extreme conditions in this process mean that it is very energy intensive with an estimated energy requirement of 2.16 to 2.38 GJ/tCO₂ of CO₂ to recover in liquid form. Typical recovery efficiencies are in the range of 90 to 95% and suitability is limited to gaseous mixtures with a high CO₂ concentration (>90 %vol) (Leung, Caramanna, & Maroto-Valer Mercedes, 2014).

Gas hydrates

Gas hydrate CO₂ separation is a relatively new technology compared to other separation methods. It is based on the principle of reacting the CO₂-containing stream with water under high pressure to form hydrate compounds. At high pressure and low temperature, the CO₂ becomes trapped within hydrate structures easier than other components in the gas. The CO₂ is subsequently removed from the hydrate structure by depressurisation or heating. Gas hydrate separation has been found to have an energy consumption of 2.6 GJ/tCO₂. Although gas hydrate separation technology is in its infancy, the US Department of Energy believe that it may be the most promising long term CCS technology (Leung, Caramanna, & Maroto-Valer Mercedes, 2014).

Mineral carbonation

Mineral carbonation utilises the alkaline earth metals (such as silicates and free lime) found in the slag produced by a BF. CO₂ reacts with these compounds to form stable compounds which can subsequently be stored. The two main carbonation processes are classified by either a direct or indirect process. Direct process carbonation reactions occur in the aqueous phase or at the solid-gas interface between the slag and CO₂-containing gas mixture. Indirect processes involve the alkaline earth metals first being isolated from the slag and then reacted with the CO₂-containing gas mixture (Abdul Quader M. , Ahmed, Ariffin Raja Ghazilla, Ahmed, & Dahari, 2015).

Membranes

Gas can be physically separated using membranes such as ceramics and metals configured in such a way that only CO₂ can pass through. This is operated as a continuous process, unlike the previous technologies which all operation in batch mode. A CO₂ capture efficiency of over 80% can be achieved with some membrane materials. Other gas components can also be

removed using membranes, such as O₂ and N₂, which can be used for other parts of the steelmaking process or sold to other industries. Membranes are currently relatively infant in their development but may have good future potential. One of the main challenges with membranes is minimising fouling and thus increasing the flux rate. Membranes have proven to be very sensitive to the gas stream properties and thus careful control of this is needed to achieve efficient operation (Leung, Caramanna, & Maroto-Valer Mercedes, 2014).

ULCOS program

The main CCS technologies that are being explored in the ULCOS programme are amine scrubbing, VPSA or PSA and cryogenics. Several factors are taken into account when evaluating the most effective CCS technology: the steelmaking technology, steam and energy prices, CO₂ purity in feed and output, and storage requirements (Abdul Quader M. , Ahmed, S, & Nukman, 2016). Another important consideration is that all of these factors are time-dependant and so evaluations must take into consideration factors such as the R&D progress predictions (e.g. decrease in energy intensity) of all technologies as well as future projections of steam and energy prices (Global CCS Institute, 2010).

In both a conventional BF and TGR-BF, physisorption-based technologies (PSA and VPSA) are found to be the most suitable with both performance and cost considered. NG-DR steelmaking processes also are found to be most suitably implemented with physisorption-based technologies. Cryogenic separation may be necessary in a subsequent stage to PSA/VPSA depending on the desired CO₂ purity for BF, TGR-BF and NG-DR technologies. HISarna produces a high purity CO₂ stream and so CO₂ capture is only required in the cases in where the CO₂ purity is required to be even higher or if the presence of impurities is high, thus requiring cryogenic separation. Overall, each steel mill needs to be evaluated on a case-by-case basis to select and optimise the CCS technology which takes into consideration all CO₂ streams and not only the primary source (Global CCS Institute, 2010).

As part of the ULCOS program, a TGR-BF pilot plant built by LKAB in Luleå, Sweden has implemented a Vacuum Pressure Swing Absorption (VPSA) system. The VPSA system was built by Air Liquide, a partner of the ULCOS program. An indirect advantage of this CCS system implemented in a BF is that the captured CO₂ from the top gas increases the concentration of reducing gas (mainly CO) that can be recycled back into the vessel and thus improves overall performance. In this pilot plant, the captured CO₂ was not stored (Global CCS Institute, 2010). The plant layout of this system is illustrated in Figure 19 (Global CCS Institute, 2010).

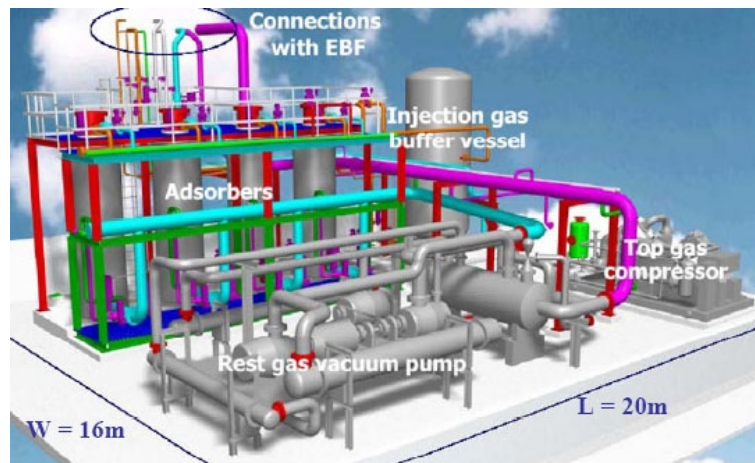

Figure 19. Plant layout of the VPSA implemented by Air Liquide in the ULCOS TGR-BF in Luleå.

Following the successful implementation of VPSA in the pilot plant as part of ULCOS I, a larger scale CCS system is being planned for ULCOS II with VPSA used in conjunction with cryogenics. This will test the scale-up effect of such a system and will also test the ability of cryogenics to achieve high CO₂ purity, as it is planned to store the CO₂ in deep saline aquifers. During the cryogenic step, reducing gas is produced as a by-product that can be recycled back into the BF for improved performance (Global CCS Institute, 2010).

In the absence of CCS, the HISarna process requires dust removal, heat recovery and de-sulphurisation processes. The addition of cryogenic-based CCS still requires these processes but with the addition of drying, separation, compression stages prior to pipeline transport and storage, as displayed in Figure 20 (van der Stel, et al., 2013).

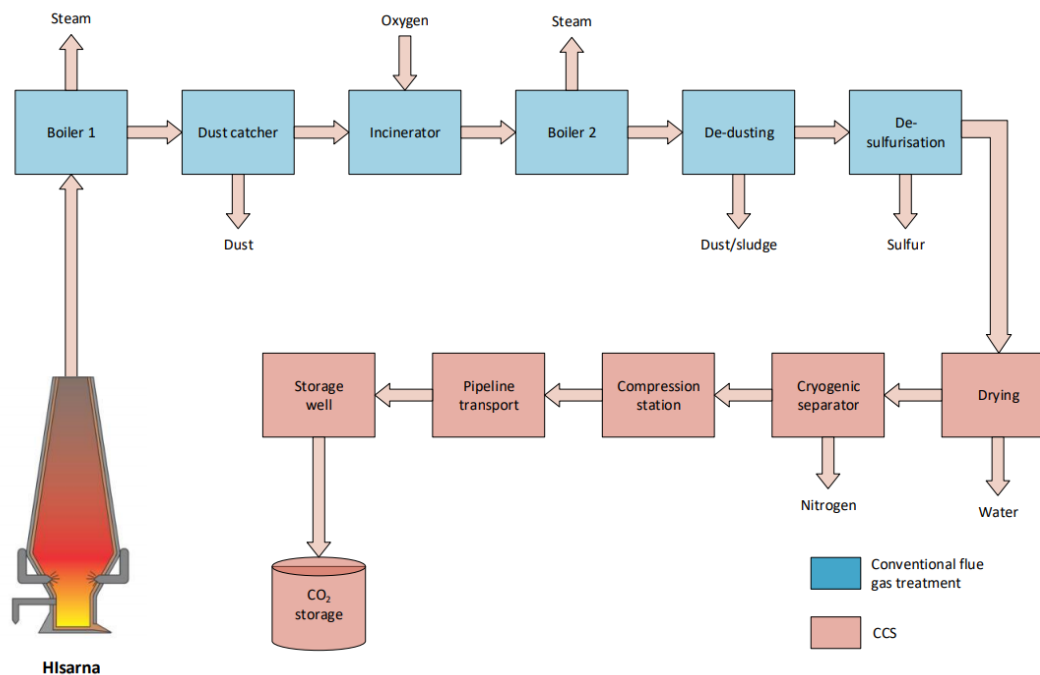

Figure 20. Systematic flowsheet of cryogenic CCS implemented to the HISarna process

The composition requirement of different storage basins is specific to each case and thus it is difficult to create universal legislation. Thus, the stream specification would need to be specified to all participating parties for each project to ensure compliance. Table 6 displays the stream composition in some existing CCS pipelines used for Enhanced Oil Recovery (EOR) (Peletiri, Rahmanian & Mujtaba, 2018). The CO₂ composition in these pipelines is in the range 85 – 99.7 mol%, this is a good indicator of the stream purity that would be expected to be achieved regardless of the source.

Table 6. Stream composition of several different existing CCS pipelines (mol%) (Peletiri, Rahmanian & Mujtaba, 2018)

	Pipeline 1	Pipeline 2	Pipeline 3	Pipeline 4	Pipeline 5
CO ₂	95	85-98	96.8-97.4	98.5	99.7
CH ₄	1-5	2-15	1.7	0.2	-
N ₂	4	<0.5	0.6-0.9	1.3	0.3
H ₂ S	0.002	<0.02	-	<0.002 wt	-
C ₂₊	Trace	-	0.3-0.6	-	-
CO	-	-	-	-	-
O ₂	-	-	-	<0.001 wt	-
H ₂	-	-	-	-	-
H ₂ O	0.0257 wt	0.005 wt	0.129 wt	0.0257 wt	-

4.1.8 CO₂ capture and utilisation

Carbon capture and utilisation (CCU) follows the same principles as CCS without the storage aspect. Instead, CCU aims to use the capture CO₂ as a feedstock to make useful products. The products can be broadly categorised into: CO₂-to-fuels, enhanced commodity production, enhanced hydrocarbon production, CO₂ mineralisation chemicals production. Extensive

research of CCU potential has been conducted by the European Commission Joint Research Centre. An overview of the main technologies currently being investigated are displayed in Table 7 (Bocin-Dumitriu, Perez Fortes, Tzimas, & Sveen, 2013). The global uptake potential is given to put into context the demand that could be available. The research and industrial engagement gives an indication about how much activity is going on within the technology and can give an indication about how much potential a technology is deemed to have. Finally, the Technology Readiness Level indicates the maturity of each technology from the basic concept (TRL 1) to being available at a commercial scale (TRL 9) (Bocin-Dumitriu, Perez Fortes, Tzimas, & Sveen, 2013). An important consideration is that in many of these applications, the CO₂ is not permanently stored, but instead is often released again in another process.

Table 7. Overview of most promising European technological pathways for CCU

CO ₂ re-use technology	Uptake potential (Mt/year)	Research & Industrial engagement	TRL
Methanol production	> 300	+++	4-6
(Carbonate) Mineralisation	> 300	+++	3-6
Polymerisation	5 - 30	+++	8-9
Formic acid	> 300	+++	2-4
Urea	5 - 30	+++	9
Enhanced coal bed methane recovery	30 - 300	+-	6
Enhanced geothermal systems	5 - 30	+-	4
Algae cultivation	> 300	+-	3-5
Concrete curing	30 - 300	+-	4-6
Bauxite residue treatment	5 - 30	+-	4-5
Fuels engineered micro-organism	> 300	+-	2-4
CO ₂ injection to methanol synthesis	1 - 5	+-	2-4

Asides from CO₂, other by-products can be utilised to make useful products. TSIJ and Dow Benelux are currently building a pilot plant that utilises carbon monoxide (CO) from the waste gases of the blast furnaces to produce syngas. Syngas can be used to produce a range of products but this pilot plant will focus on naphtha, a hydrocarbon mixture that Dow use to make chemical products. TSIJ claims that they can supply around 5% of the current naphtha production by Dow. Producing naphtha is a higher value application than the production of electricity and the emissions of doing so would no longer be included within the steelmaking plant, an advantageous attribute for the steelmaker. Several other major European steelmakers are also working on similar projects (De Ingenieur, 2018).

4.1.9 Steel recycling

TSIJ recycles approximately 1.4 Mt of steel, both internally and externally sourced, in 2015. Scrap steel is inputted in to the BOF alongside pig iron from the BF. The use of scrap steel significantly reduces CO₂ emissions from production but is subject to significant constraints on availability and cost. EAFs can be run entirely on scrap steel and currently account for 30% of global steel production and so competition for material is rife (World Steel Association, 2018). Hence, decarbonisation options with an EAF provide the opportunity to greatly increase the level of scrap steel used provided that there is sufficient availability.

4.1.10 Energy efficiency

TSIJ have an energy efficiency program entitled *Trias Energetica* which consists of three main goals:

1. Reduce unnecessary energy consumption, e.g. heat insulation, start-up/shut-down procedures, design innovation.
2. Use sustainable energy sources for necessary energy consumption, e.g. wind, solar, biomass.
3. When sustainable energy sources are not possible, utilise more efficient, less pollutant fossil fuel sources, e.g. natural gas instead of coal.

A combination of these energy efficiency measures have helped TSIJ improve their energy efficiency by 32% since 1989. This is illustrated in Figure 21 and compared to steel mills deemed 'world class' in terms of energy efficiency, showing that TSIJ is one of the most energy efficient steel mills in the world (Jägers & Kiesewetter, 2018). However, further incremental energy efficiency measures are becoming more difficult and thus larger, step-change technological investments are required to improve energy efficiency further (Jägers & Kiesewetter, 2018).

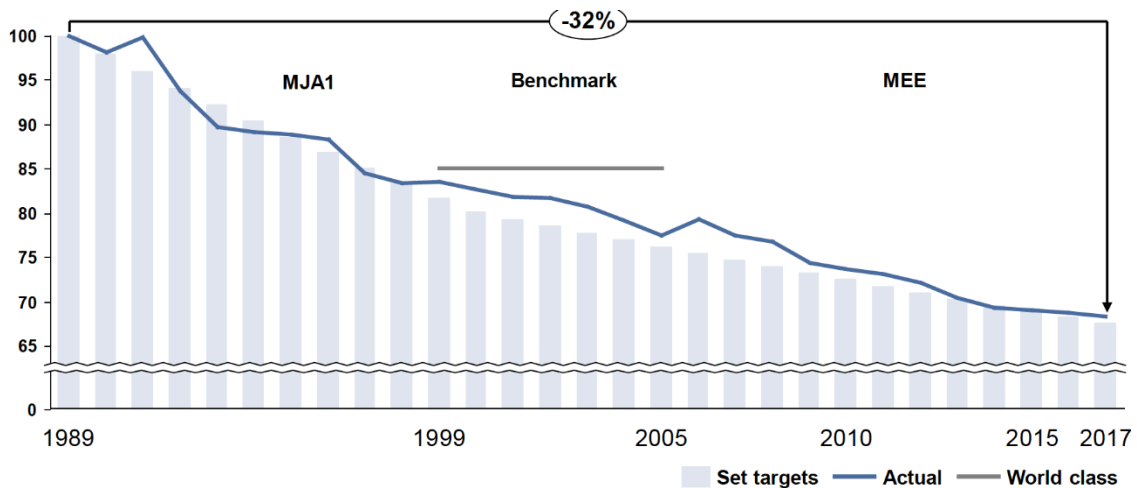

Figure 21. Energy efficiency of TSIJ overall processes relative to 1989

4.2 Material, energy and CO₂ flows

An overview of the material, energy and CO₂ flows for the selected decarbonisation options are formed using a range of sources specifically for each technology. Details of use of hydrogen in ULCORED are not available and hence will be stated as a general hydrogen direct reduction (H-DR) option. Alongside these alternative technologies, the use of existing EAF technology alone is also a valid option and hence is included. An explanation of how the flows have been devised are provided one-by-one in this section. For all options, processes that are present in the current situation at TSIJ are scaled linearly to meet 1 Mt of crude steel production. See section 3.2 for an explanation of how these values were devised alongside the CO₂ emission calculation methodology. All excess WAGs are assumed to be combusted in an on-site CHP plant with 40% efficiency and a 1:1 electricity-to-heat ratio. It is also assumed that in the absence of any process gases, they are substituted by natural gas. All options are shown schematically in Figure 22 - Figure 28.

EAF

The flows of this option are based on (EIPPCB, 2013) in which it is assumed that the process is based entirely on scrap steel. Average values are taken for all flows.

TGR-BF

The flows from the TGR-BF unit are based on version 4 from (Danloy, van der Stel, & Schmöle, 2008). It is assumed that an equal share of sinter and pellets is used, analogous to what is currently practiced at TSIJ. A modification is made in that 90% top gas recycling rate is assumed, in-line with the results in (Junjie, 2018). The remaining 10%, alongside the tail gas of the VPSA, have an energetic content that is assumed to be used for the preheating of the recycled top gas. The energy density of both streams are calculated based on the value per Nm³ from (Danloy, van der Stel, & Schmöle, 2008): 6.9 MJ/Nm³ for the 10% unrecycled top gas and 1.5 MJ/Nm³ for the tail gas of the VPSA.

HIsarna

There is a lack of specific data for the HIsarna option, hence, several assumptions were required to be made. The iron ore requirement is assumed to be analogous to the other processes, in which little variation is present between options. The coal requirement is assumed to 80% of the stated typical blast furnace coal requirements ($17 * 80\% = 13.6$ GJ/t HRC) from (Croezen & Korteland, 2010). The electricity demand is taken from X. The oxygen requirements are calculated by performing a basic mole balance calculation based on the equation of $C + O_2 \rightarrow CO_2$ assuming that the top gas is almost 100% CO₂. Working backwards from the CO₂ emissions arising from the HIsarna reactor, the oxygen requirements are calculated assuming an oxygen density of 1.331 kg/Nm³. The electricity requirements are assumed to be in the same range as that in the TGR-BF. It is assumed that 100% of the CO₂ is captured.

ULCORED

A ULCORED reactor based on natural gas has been primarily based on a simplified version of (Sikstrom, 2013). Due to the absence of a coke plant for this option, coke breeze has been substituted for coal in the pellet plant. The DRI and scrap steel flow into the EAF has been based on (Daniels, 2002).

H-DR

The flows in this option have been based on (Hölling & Gellert, 2018). It has been assumed that all iron ore requirements are met with pellets (although it may be also possible to use sinter). The flows in the water electrolyser to produce the required volume of hydrogen have been devised from a basic mole balance calculation.

ULCOWIN & ULCOLYSIS

All flows in both options are based explicitly on (European Commission, 2016).

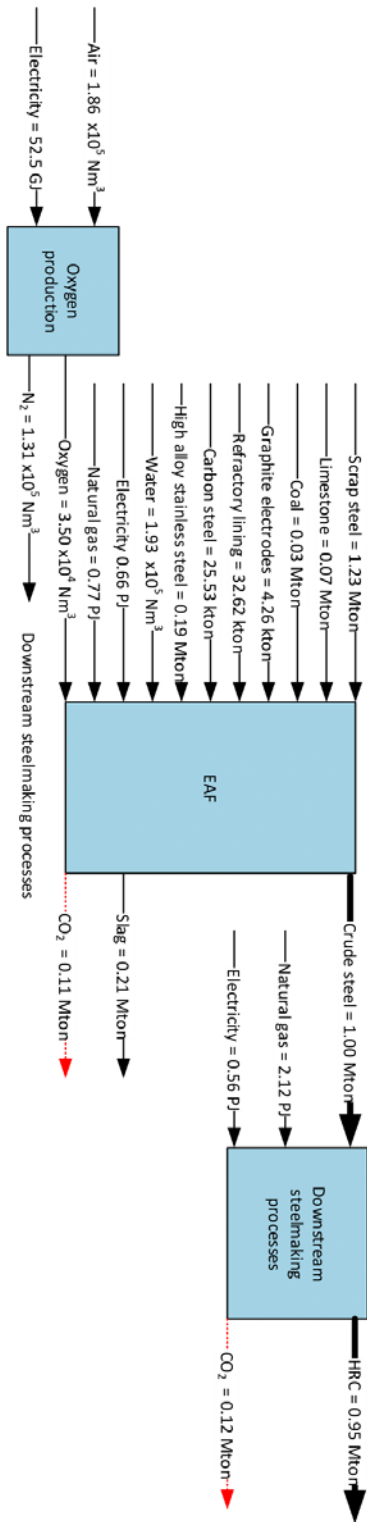

Figure 22. Flowsheet of the EAF steelmaking route

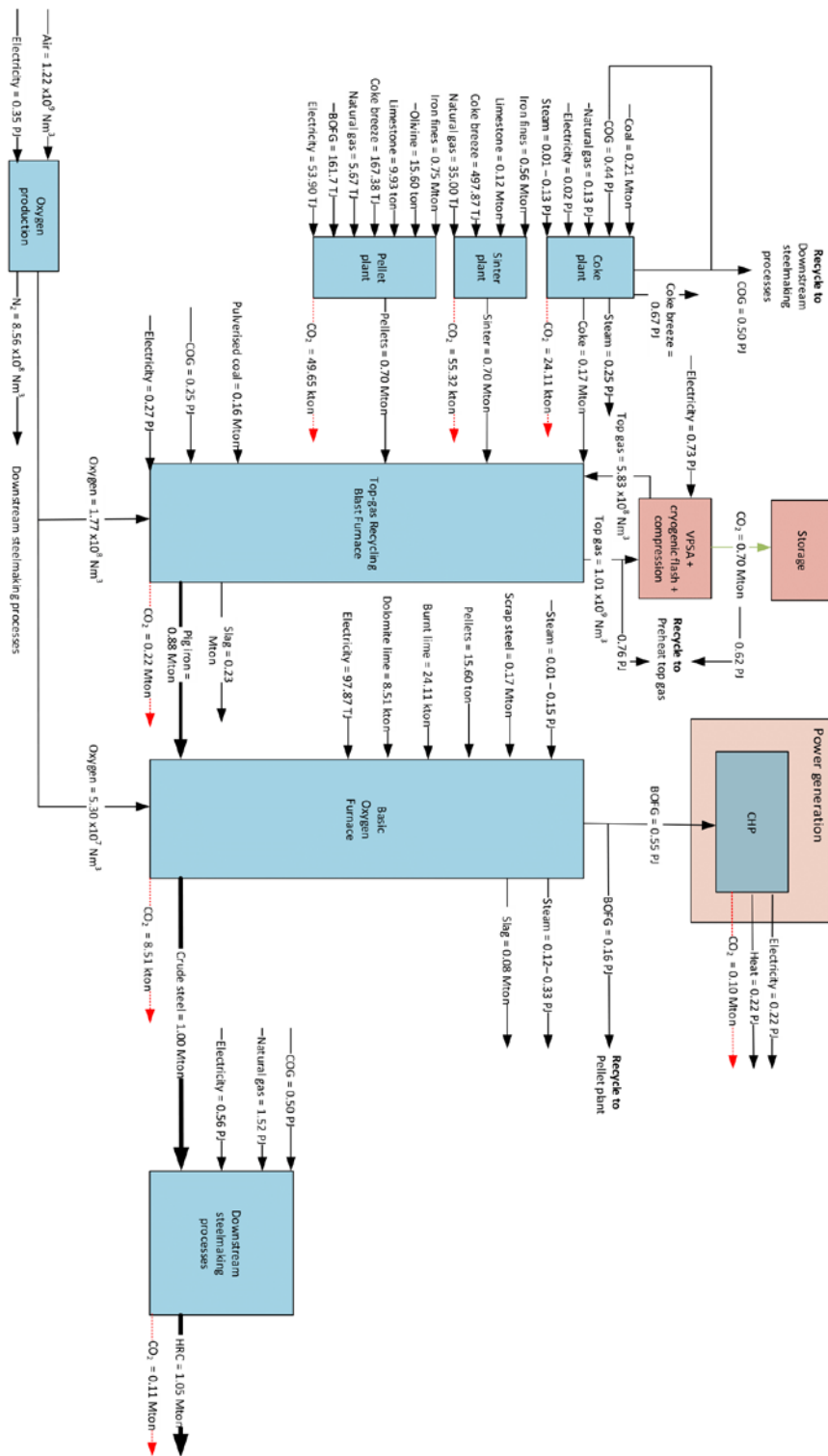

Figure 23. Flowsheet of TGR-BF (version 4) steelmaking route

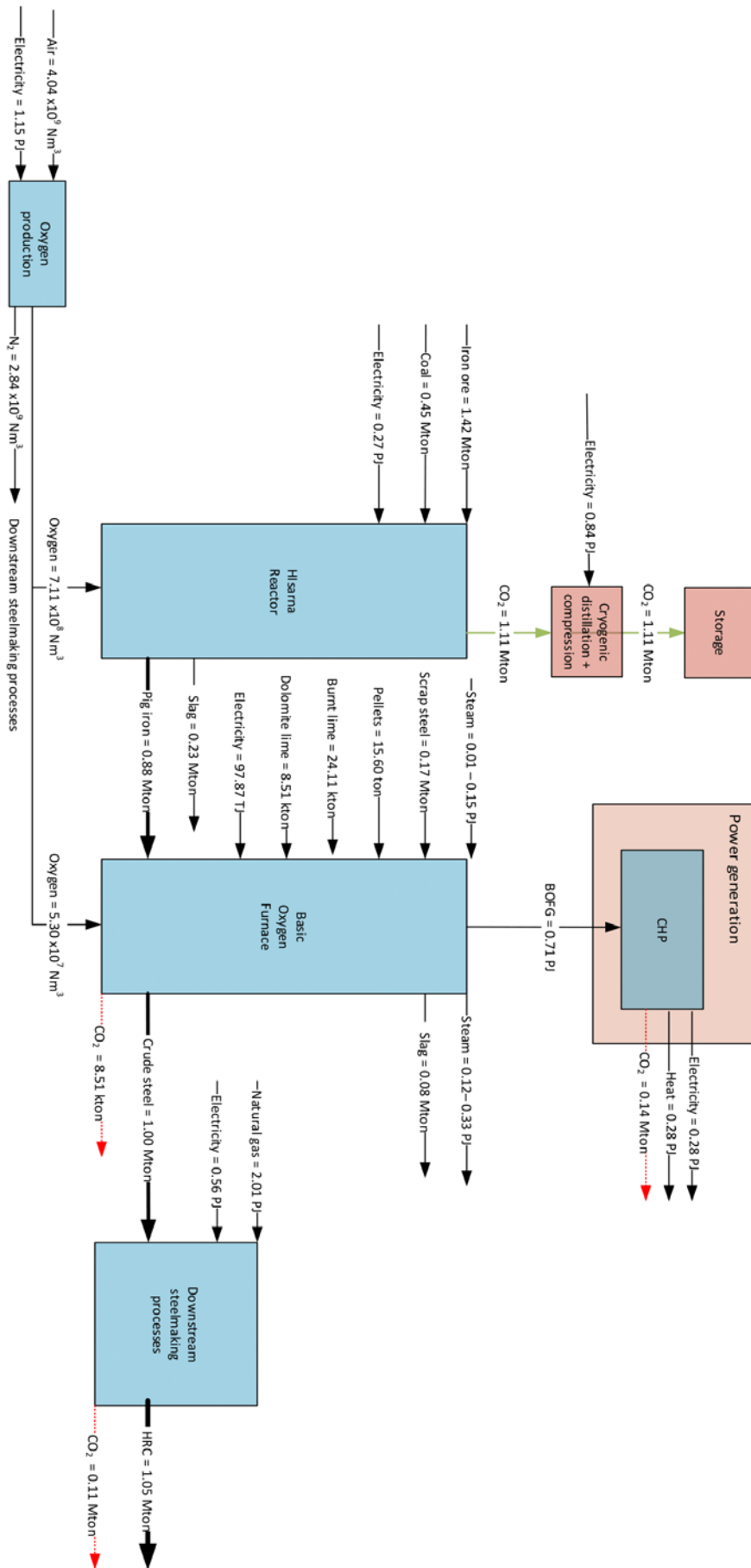

Figure 24. Flowsheet of the HISarna steelmaking route

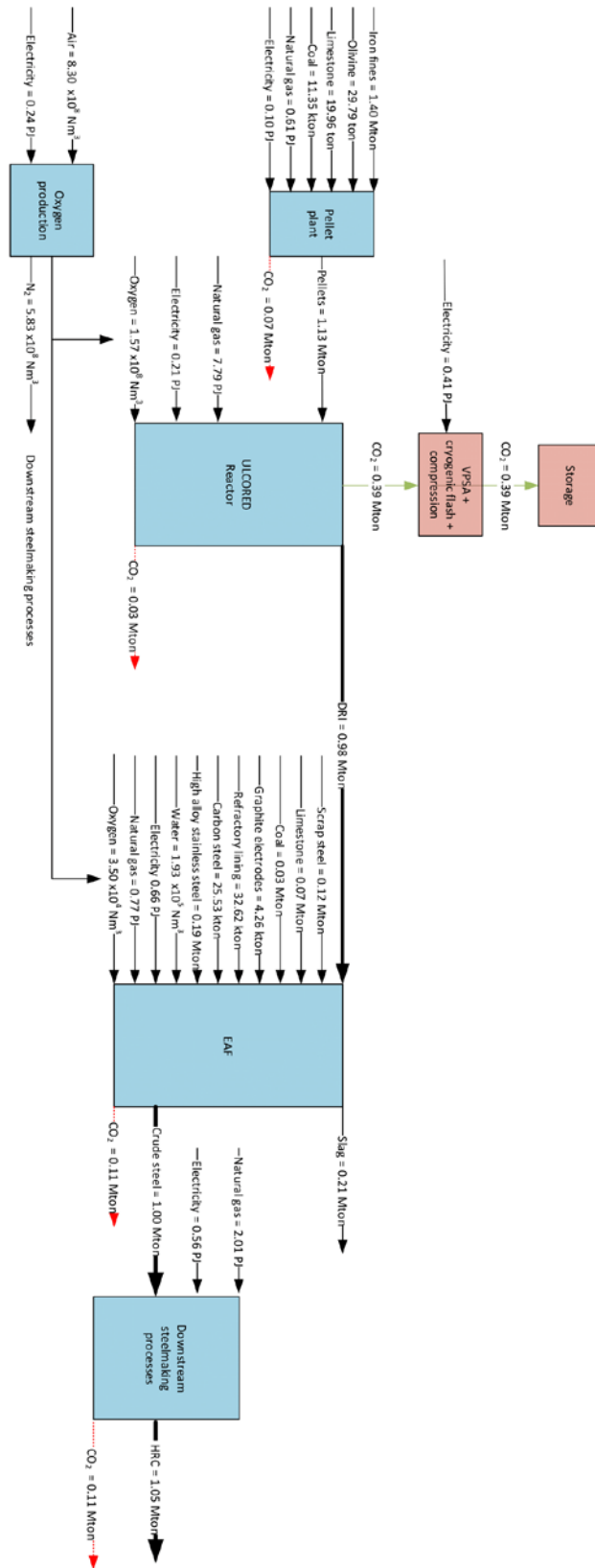

Figure 25. Flowsheet of the natural gas-based ULCORED steelmaking route

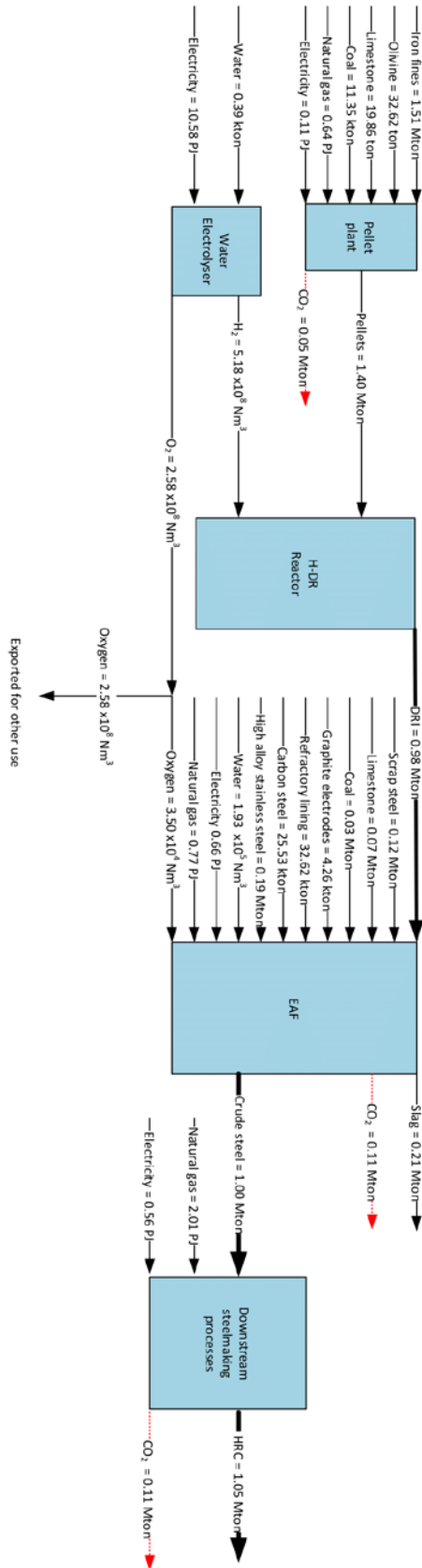

Figure 26. Flowsheet of the H-DR steelmaking route

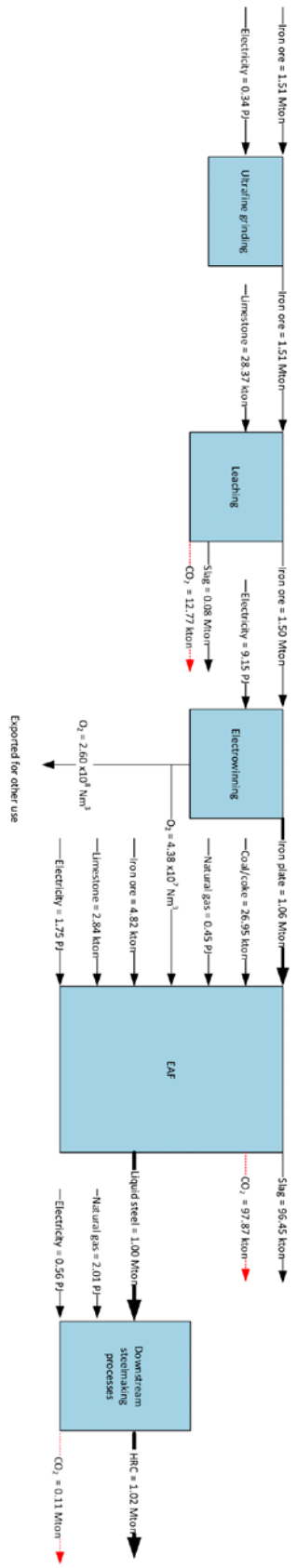

Figure 27. Flowsheet of the ULCOWIN steelmaking route

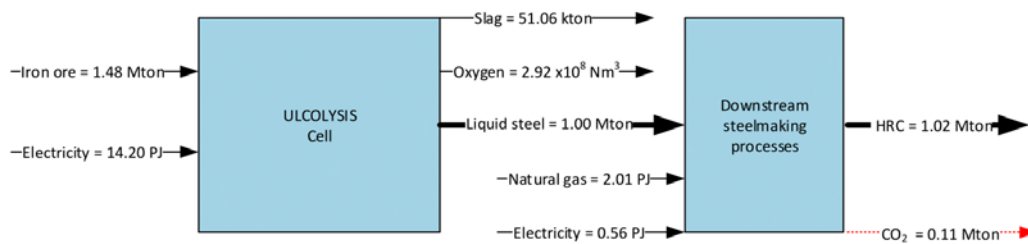

Figure 28. Flowsheet of the ULCOLYSIS steelmaking route

CCS plays an important role in several decarbonisation options for emission reduction and its energy requirements differ for each technology, hence, it is important to provide explanation to how the energy requirements have been derived for this report. The addition of CO₂ capture can be applied to the BF/BOF, HIsarna and ULCORED and is an integral component to TGR-BF steelmaking technology to achieve significant CO₂ reduction. There are a range of CO₂ capture technologies that can be applied to each steelmaking technology, each with their own pro's and con's. The flue gas from HIsarna differs relatively substantially from the other technologies due to its high CO₂ purity (~95%) (Brownsort, 2013). Depending on the required CO₂ purity for storage, it may or may not be necessary to include a CO₂ separation unit. If a higher CO₂ purity is required then it is likely to only require cryogenic separation alone, otherwise HIsarna only requires pre-treatment stages and compression before storage. A system-level flowsheet of how cryogenic separation and storage can be applied to HIsarna is displayed in Figure 20.

The assumptions of the CO₂ capture technology that has been selected for the purpose of this report and the associated characteristics are listed in Table 8, based on what is most commonly considered to be most suitable both technically and economically. The CO₂ capture rate in the case of BF/BOF is assumed based on (Gazzani, Romano, & Manzolini, 2015) and in HIsarna a 100% capture rate is assumed. The CO₂ capture rate for the other steelmaking technologies has been calculated, rather than assumed, based on the material flows used from literature. The effective CO₂ concentration range in flue gas for each CO₂ capture technology is estimated based on their common applications. For example, cryogenic flash separation is commonly used to treat high CO₂ purity streams and amine-based separation is commonly used for combustion flue gases with low CO₂ purity. Table 9 displays the energy requirements of the selected CO₂ capture technologies, all of which are based on (Global CCS Institute, 2010), except cryogenic distillation which is based on (Leung, Caramanna, & Maroto-Valer Mercedes, 2014). Figure 29 displays the main stages involved for CCS applied to flue gas sources, beginning with several pre-treatment stages, followed by the main CO₂ separation unit, and finally compression to 100 bar for storage (Hoa, Bustamantea, & Wileya, 2013). These general stages are applicable to all capture technologies considered and outlines the scope when energy and costs are considered.

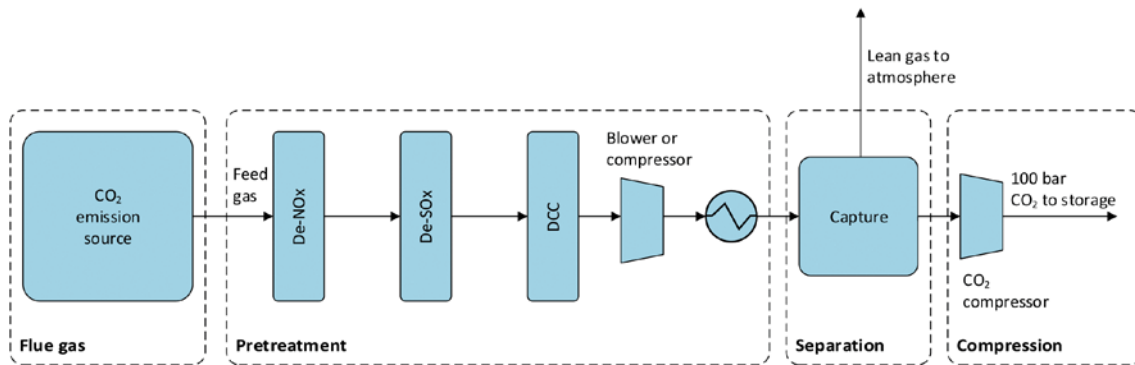

Figure 29. Scope of CO₂ capture process

Table 8. CO₂ capture technology assumptions for steelmaking processes

Steelmaking process	CO ₂ capture technology	Location	Capture rate (%)	Effective CO ₂ concentration in flue gas (%)
BF/BOF	SEWGS + compression	BF	90%	Low (<15 vol%)
TGR-BF	VPSA + compression + cryogenic flash	TGR-BF	94%	Medium (15-55 %vol)
HIarna	Cryogenic distillation + compression	HIarna reactor	100%	High (>90%)
ULCORED	VPSA + compression + cryogenic flash	ULCORED reactor	94%	Medium (15-55 %vol)

Table 9. Energy requirements of CCS technology configurations

	VPSA + cryogenic flash + compression	Cryogenic distillation + compression	SEWGS + compression
Electricity consumption (GJ/t CO ₂)	1.05	2.16	2.24
Capture process (GJ/t CO ₂)	0.58	1.75	-
Compression for storage at 110 bar (GJ/t CO ₂)	0.48	0.41	-
Total energy requirement (GJ/t CO₂)	1.05	2.16	2.24

Considering the energy flows constructed for the selected decarbonisation options, a comparison of the total energy consumption and generation is calculated. This not only includes energy consumed as a fuel but also the energy of chemical feedstocks, e.g. coke as a reductant in the blast furnace. The total energy consumption and generation is divided into coal, natural gas and electricity for each option. The comparison is displayed in Figure 30. Note: the steam requirements for CCS in the BF/BOF configuration is accounted for by assuming an electric boiler efficiency of 100% to produce low pressure steam. It is also possible that high temperature heat pumps that inhibit a higher efficiency could be used instead, depending on

the temperature required. It is likely that there is waste heat available on-site that could be utilised to produce steam, however the quantity is not known.

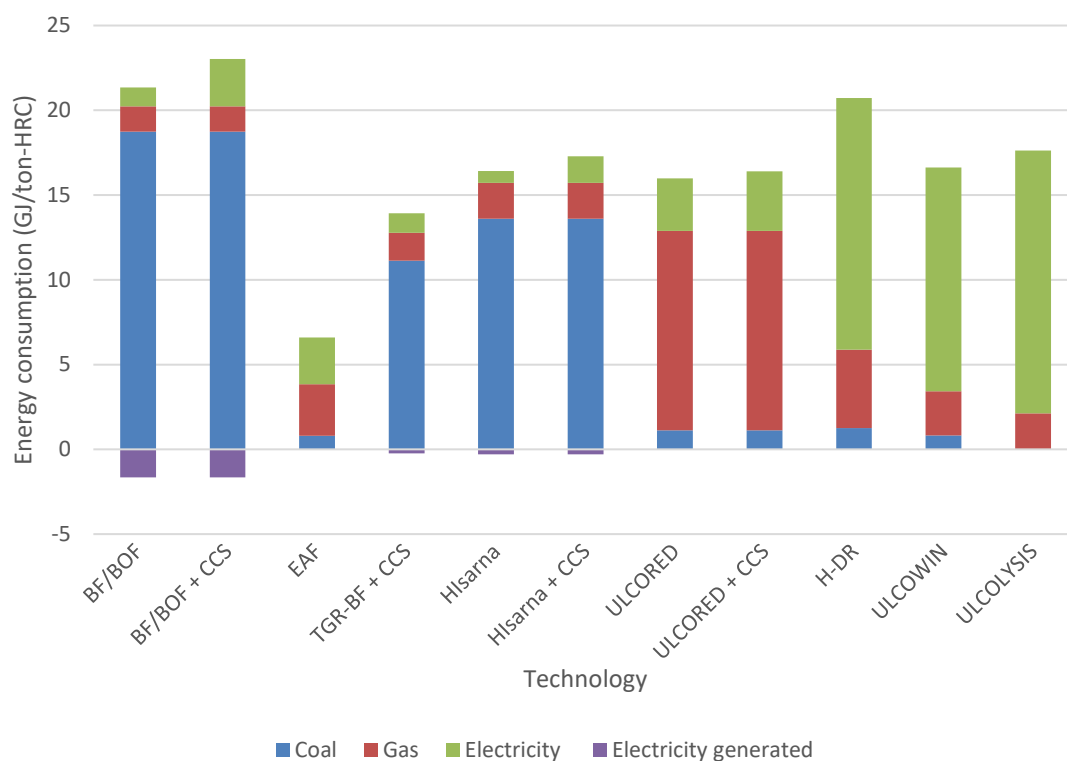

Figure 30. Annual energy consumption of decarbonisation options relative to the current BF/BOF process

The resulting CO₂ emissions are calculated with the same methodology as in section 3.2. To allow for more consistent comparison, all results are given per Mt product of HRC (hot rolled coil) of steel. Figure 31 displays a comparison CO₂ emissions emitted for decarbonisation options including CCS where applicable. Figure 32 displays the CO₂ emissions emitted calculated for the relevant decarbonisation options with charcoal substitution at both a lower and upper limit. Table 10 displays the charcoal substitution limits based on Table 5.

Table 10. Assumed upper and lower limit of charcoal substitution per process for applicable decarbonisation options

Steelmaking process	Fossil fuel substituted	Lower charcoal substitution rate (%)	Upper charcoal substitution rate (%)
Sinter plant	Coke breeze	50	100
Pellet plant	Croke breeze	50	100
Blast furnace	Pulverized coal	50	100
Blast furnace	Coke	2	10
HIsarna reactor	Coal	20 ¹²	40

¹² The lower bound is estimated as half of the upper limit goal of 40% by TSIJ.

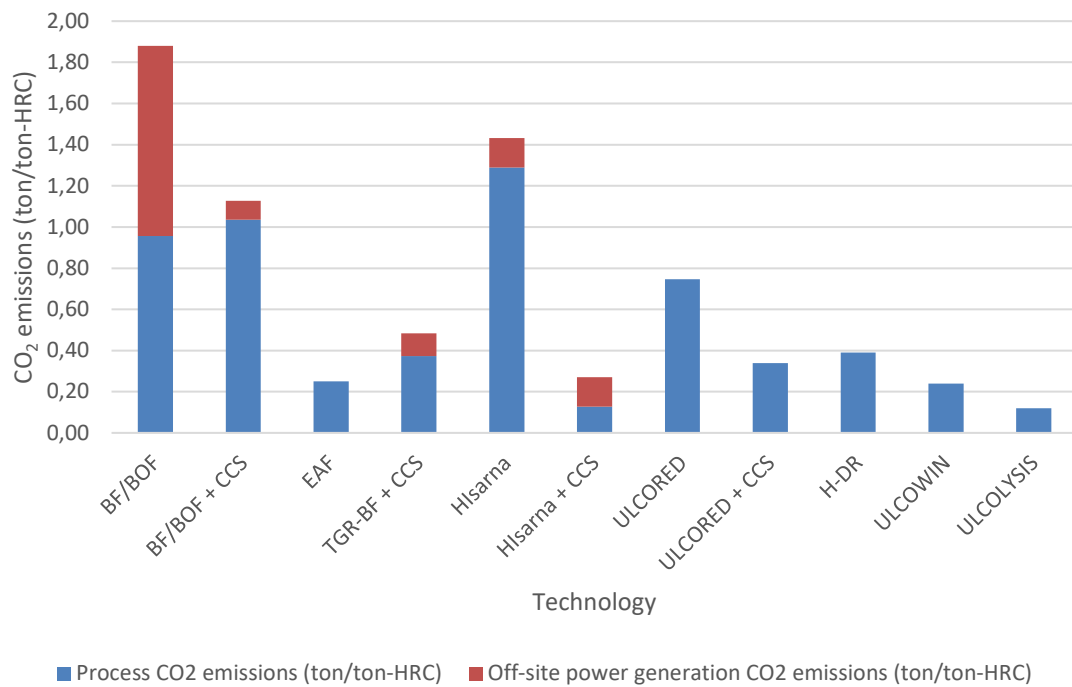

Figure 31. Comparison of CO₂ emission estimates for steelmaking technologies (excl. biomass implementation)

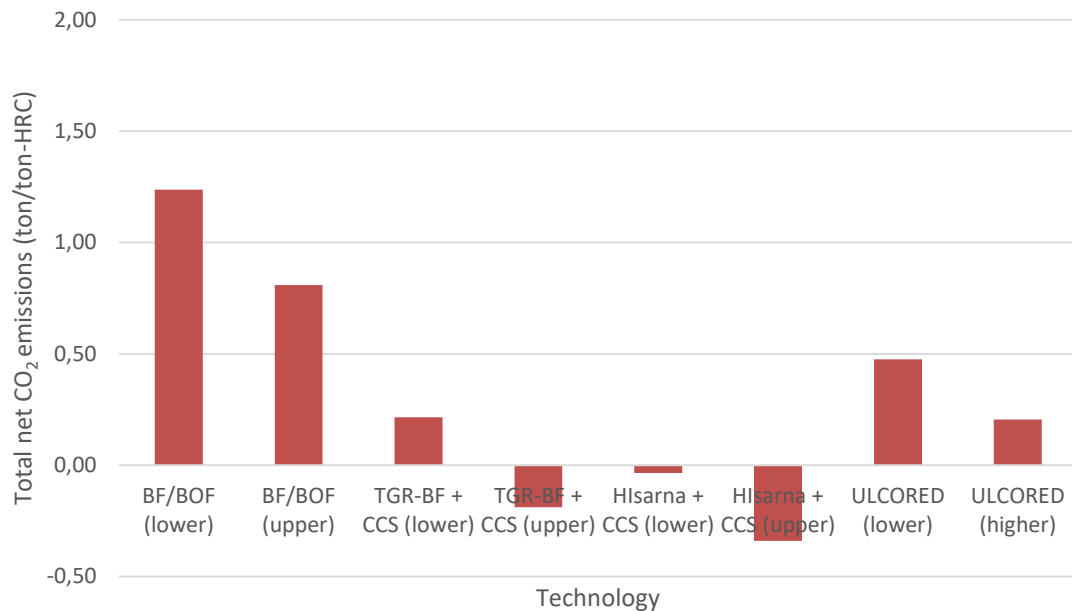

Figure 32. Comparison of CO₂ emission estimates with charcoal substitution in the most feasible steelmaking technologies

4.3 Investment and operating costs

The European Commission (2016) provides the most comprehensive production cost comparison of the concerned technologies of this report. The production costs are divided into capital, raw materials, energy and other non-energy costs and this forms the basis on the production cost analysis. The assumptions regarding the capital, raw material and non-energy costs, such as equipment lifetime, raw material costs and CCS technologies are unknown from the data but the consistency and scope is the most suitable available literature and so the values are utilised. Please note that all costs are in terms of tonnes of Hot Rolled Coil and so are also assumed to include post processing stages.

BF/BOF with CCS retrofit is missing from this data and so an estimate of the total cost of CCS to the baseline cost of BF/BOF is estimated from (Hoa, Bustamantea, & Wiley, 2013) where the overall cost of CO₂ capture for this configuration with amine CCS technology at a WAGs power plant is EUR 56/t CO₂. The breakdown of the overall CO₂ capture costs into capital, raw materials and other is shown in Figure 33 (Hoa, Bustamantea, & Wiley, 2013). Therefore, an estimate of these costs can be derived from this information alongside the calculated CO₂ reduction potential as follows:

$$\begin{aligned} \text{specific cost of CCS retrofit} \left[\frac{EUR}{ton_{HRC}} \right] \\ = \text{overall CO}_2 \text{ capture cost} \left[\frac{EUR}{ton_{CO_2}} \right] \times \text{cost breakdown (\%)} \times \text{CO}_2 \text{ reduction} \left[\frac{ton_{CO_2}}{ton_{HRC}} \right] \end{aligned}$$

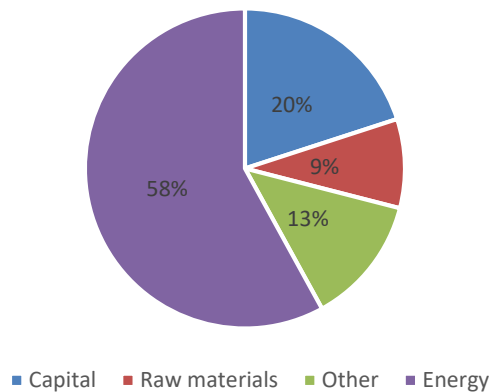

Figure 33. Cost breakdown for CO₂ capture (MEA solvent) at a conventional steel mill power plant

The European Commission (2016) provides the annualised investment capital costs and is absent of the associated discount rate or equipment lifetimes assumed to convert this to an overnight investment capital cost. Hence, to calculate the total overnight investment capital costs of each technology, a discount rate of 5% - 10% and a universal equipment lifespan of 10 - 15 years are inputted. This produces a range of estimate values as displayed in Figure 34. It is important to note that these ranges are estimates of the range of overnight investment costs rather than absolute cost ranges. Due to the majority of decarbonisation options unimplemented at an industrial scale current, investment costs are difficult to obtain and cost estimates that do exist come with huge degrees of uncertainty.

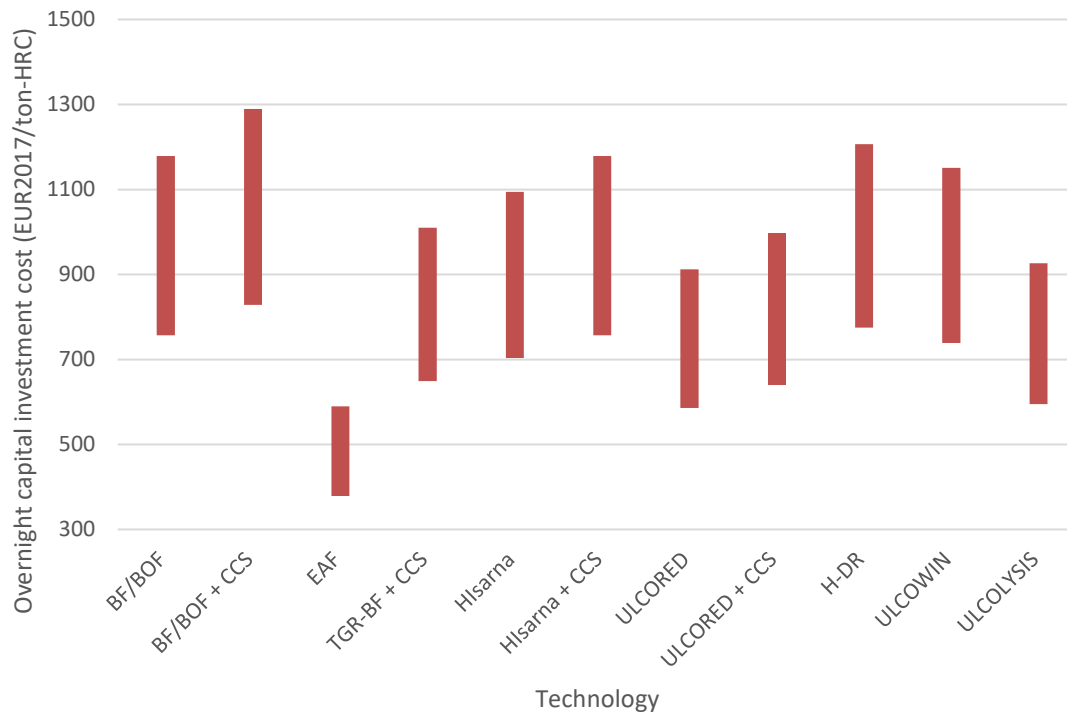

Figure 34. Overnight investment cost estimation of steelmaking decarbonisation technologies

Figure 35 displays the operating costs in terms of raw material and other. The assumptions behind other operating costs are not explicitly known but can be assumed to primarily represent fixed operating costs. The scrap-based EAF option has the highest operating costs owed to its reliance on relatively expensive scrap steel.

The associated energy costs for each option is out of the scope of the MIDDEN database. However, these costs are a significant part of the total operating cost. Hence, it is appropriate to show some examples as to what extent energy costs could have on each option. To do so, average national energy costs in 2017 (TenneT, 2018) and two different national energy cost scenarios (high and low) for 2030 and 2050 (CPB & PBL, 2016) are inputted to calculate possible total annual energy costs in the future. The impact that these scenarios have on the total annual energy costs for each option are displayed in Figure 36 - Figure 40. For the steelmaking processes primarily based on electricity (H-DR, ULCOWIN and ULCOLYSIS), the energy costs are relatively high in all cost scenarios. This is one of the most significant factors that must be taken into account when considering the implementation of these technologies.

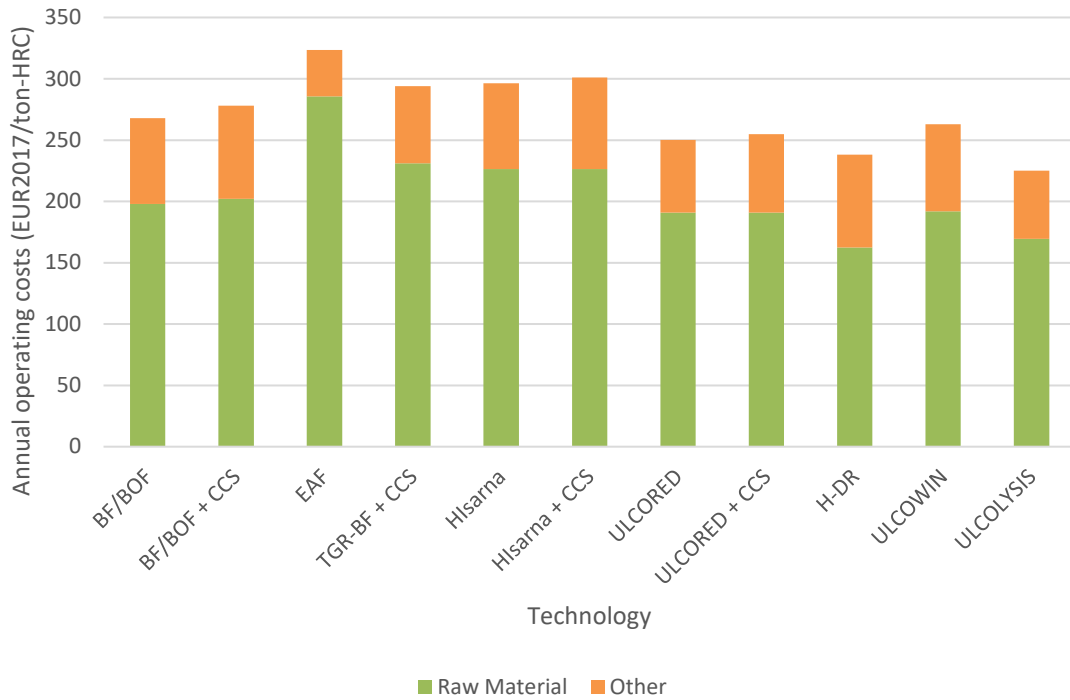

Figure 35. Annual operating costs of decarbonisation options (excluding energy)

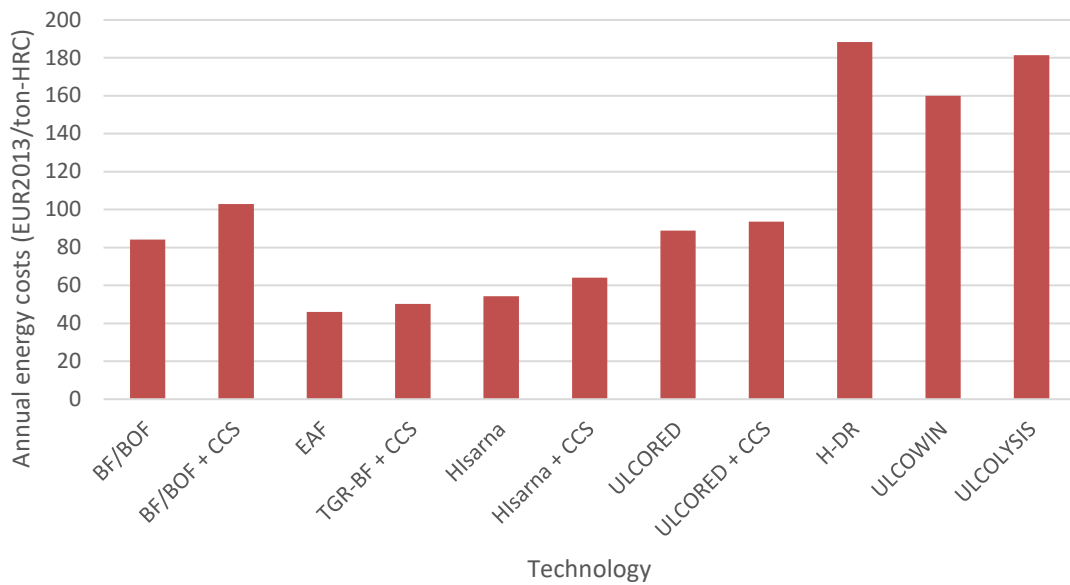

Figure 36. Annual energy costs for steelmaking options based on 2017 historical prices in the Netherlands

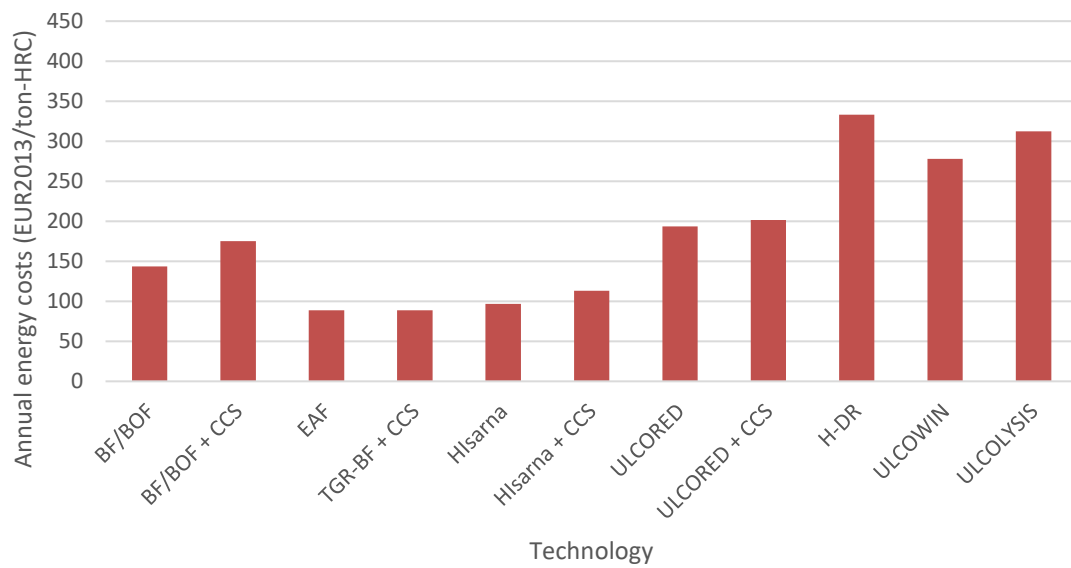

Figure 37. Annual energy costs for steelmaking options based on a 2030 low energy cost scenario in the Netherlands

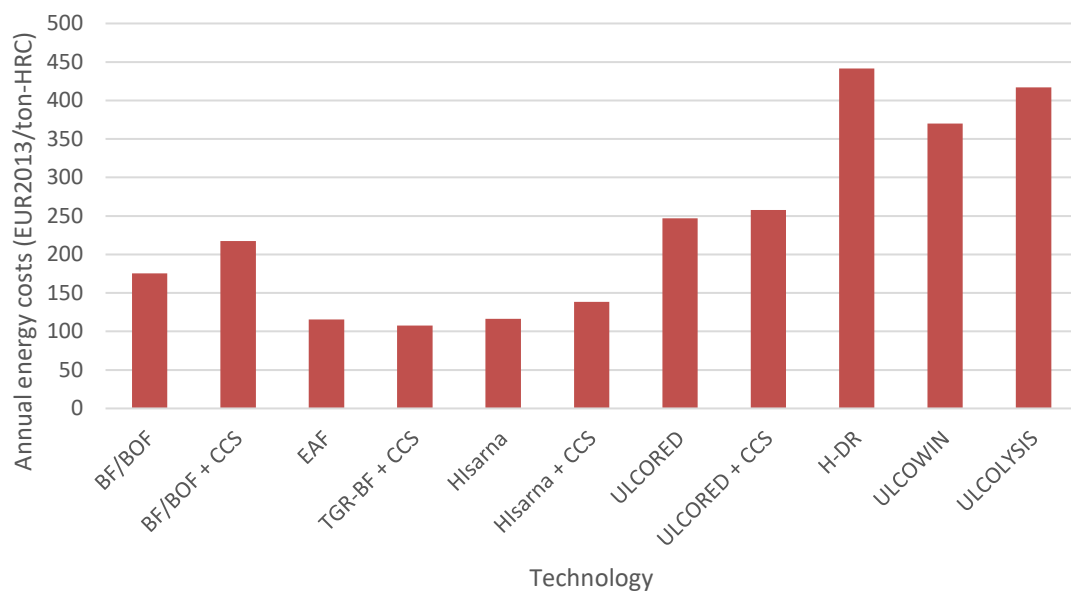

Figure 38. Annual energy costs for steelmaking options based on a 2050 low energy cost scenario in the Netherlands

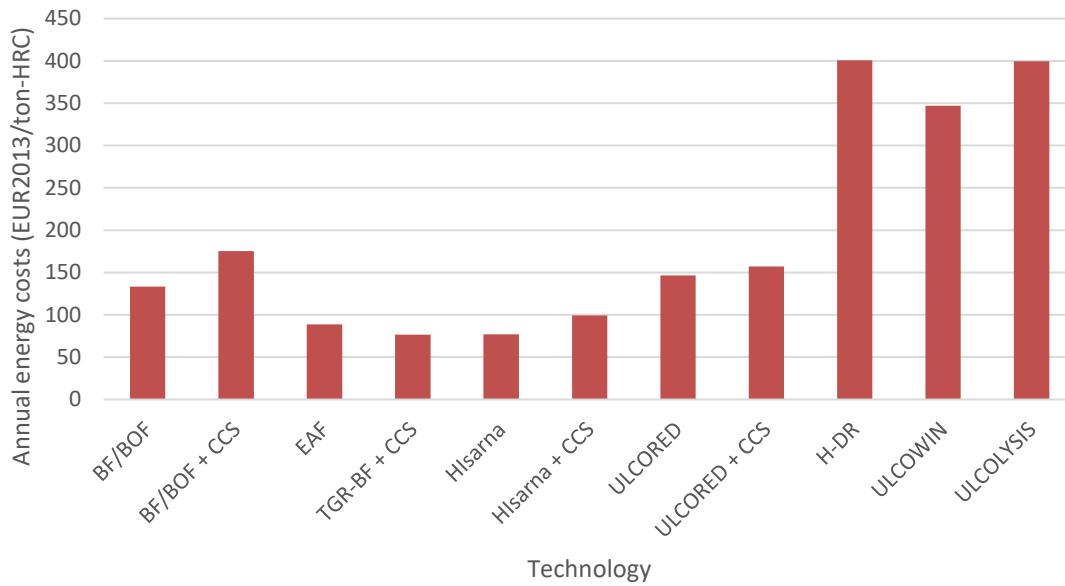

Figure 39. Annual energy costs for steelmaking options based on a 2030 high energy cost scenario in the Netherlands

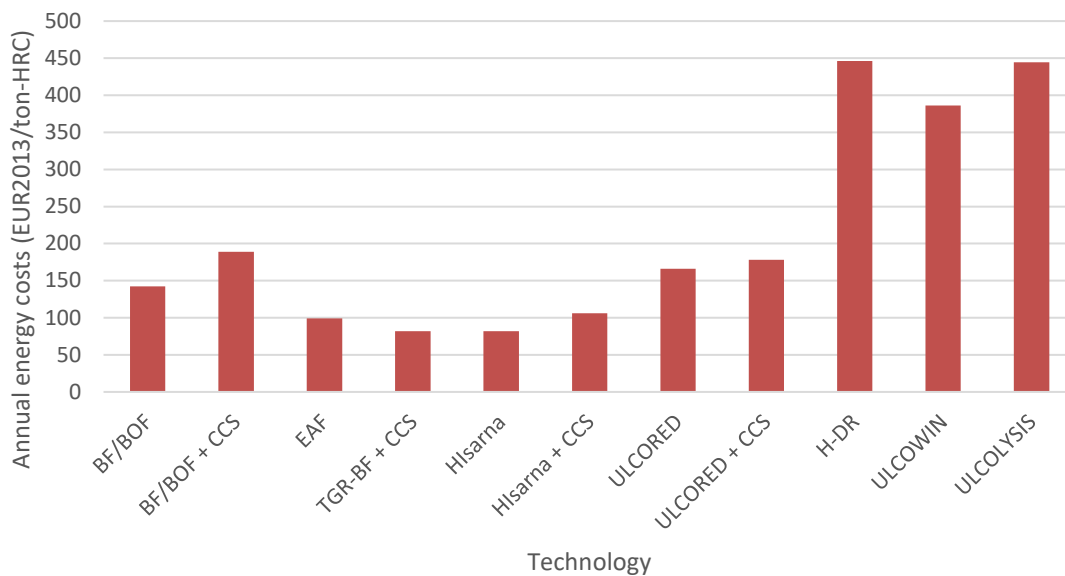

Figure 40. Annual energy costs for steelmaking options based on a 2050 high energy cost scenario in the Netherlands

Conclusions should not be drawn entirely on estimated operating and overnight capital costs because these rely on assumptions that may not be achieved in the future, primarily those technologies with a lower TRL level such as the electrolysis-based options. In the following chapter, a discussion on decarbonisation technology selection for the Dutch steelmaking industry is given which takes into account other important decision-making factors such as physical constraints of site space, cost of additional infrastructure and technology readiness.

5 Discussion

This section intends to discuss the gathered information thus far and how this applies specifically to the Dutch steelmaking industry's investment decisions required to meet the latest Dutch climate goals. The only existing Dutch steelmaking site situated in IJmuiden has its own unique characteristics and requirements and so needs to be evaluated individually and not on a general European level.

5.1 Current steelmaking process

The BF process has dominated the steelmaking industry in the Netherlands since the construction of the first site in 1918. It has greatly improved in efficiency in the past few decades and the sites are now able to significantly reduce waste material and waste energy streams, making operation both more environmentally-friendly and economical. The climate goals at both a European and national level will require this process undergo change in the near future to dramatically reduce CO₂ emissions. This will require major investment decisions in which the choice of (commercially available) technology and implementation greatly effects the future of the business.

5.2 Decarbonisation options

The decarbonisation options require varying levels of infrastructure change, some options eliminate the need for some pre-processing units and others require an entirely new infrastructure, especially in the case of the hydrogen and electricity-based options. At the current site, operation is relatively independent with most raw materials being produced on-site. Some decarbonisation options may require materials and infrastructure that may decrease independency and make Tata Steel more vulnerable to external factors. The current dominant primary energy carrier is coal, the price of which follows the global market and thus changes in the price effects all primary steel producers in a relatively similar way. A shift to natural gas or electricity-based options would potentially create a less level playing field with natural gas prices following regional trends and electricity following a more national/cross-national trend. So, the price risks of Dutch steel making will deviate from those of foreign competing companies. Hence, there is greater probability of steelmaking having geographical migration.

The economics of decarbonisation is often the focal point in discussion. However, the social acceptance of different options is often a trumping factor. Regardless of the reality of a situation, how it is perceived from the outside is extremely important. Decisions are not solely made at the steel mill, they require a great deal of acceptance both within the government, EU, NGO's and the local community. Resistance from either of these parties can put an end to a project regardless of it being the best economically or logistically. This stresses the importance of Tata Steel to involve a wide range of stakeholders in the decision making process.

The following subsections will discuss the implementation of decarbonisation options described in Chapter 5 specifically to TSIJ.

Top gas recycling furnace

The TGR-BF process utilises all of the current site processes with only modifications to the blast furnace required achieving a lower coking rate and a more concentrated CO₂ waste stream for CCS. However, in practice, carrying out major modifications to the blast furnace will cause a long outage period which is highly undesirable given the profit margin and steel output rate aims. Alongside this, a TGR-BF pilot plant operated by ArcelorMittal in Florange (France) has since been shut down and so speculation around the technology's industrial scale-up remains. Hence, this option is not looked at favourably at the time of publication of this report (Van der Meulen & Leerentveld, 2019).

HISARNA

The smelting reduction process refers to HISarna technology in which the only pilot plant is currently operating at TSIJ with an output of 60,000 thm/year. The scale-up of this pilot plant will be built in Jamshedpur, India. The plant is planned to initially produce 400,000 thm/year with a scale up to 1 million thm/year eventually. The relocation decision is likely owed to cheaper labour and increasing demand for steel in Asia, whereas growth is more stagnant in Europe. This does not necessarily mean that it will not also be built in the future in IJmuiden but it may act as a trial in which its success could determine whether a similar scale-up will replace the blast furnaces in IJmuiden. The HISarna process eliminates the need for the pre-processing plants and does not require significant electricity demand. The flue gas has a high CO₂ purity making it suitable for CCS, an ultimately necessary step for this technology.

Direct reduction process (UCLORED, H-DR)

Directly reduced iron production already accounts for approximately 7% of global iron production and EAF's are required to process further into crude steel (World Steel Association, 2018). Current directly reduced iron is entirely produced with natural gas as the reducing agent. The substitution of hydrogen as the reducing agent is gaining significant attention in research and projects such as HYBRIT in Sweden are gaining momentum. HYBRIT is a project jointly led by Vattenfall, LKAB and SSAB with the aim of producing fossil-free steel by 2035 (HYBRIT, 2019). For this option Tata Steel would need to gain connection to the Dutch hydrogen grid, and an enormous quantity of hydrogen would need to be available to continue to produce the current level of steel production. Due to the lower carbon intensity of natural gas compared to the current coal-based blast furnace process and the option of combining with CCS, this may be an option to sufficiently reduce carbon emissions with the option of switching to hydrogen at a later date when it becomes more economically and sufficient quantity can be supplied. This technology is estimated to use 75 PJ/year of natural gas to meet TSIJ current production levels, hence the price of energy is of high importance for this option.

ULCOWIN and ULCOLYSIS

The development of iron ore electrolysis technologies is still relatively premature with only very small-scale demonstration production being achieved currently. With approximately 88 and 106 PJ/year of electricity required for each option respectively to meet current production levels at TSIJ, a low electricity price is essential to make this option economically feasible. This magnitude of electricity is currently very unrealistic in the Netherlands and so significant electricity generation and transmission must be planned if this option is to be considered in the future. Due to this, these options are not being considered at this moment at TSIJ (Van der Meulen & Leerentveld, 2019).

CO₂ capture and storage

CCS is an essential technology for many of the decarbonisation options and the initiation of the Athos project may signify a preference towards these technologies. The initial estimated CCS potential of 5±1 MtCO₂/year is a significant quantity compared to the current total emissions. Further details, including costs, of this project are yet to be released but may be comparable to the Porthos project based in the Port of Rotterdam. It primarily intends to transport CO₂ from industrial partners via pipelines to be stored in offshore gas reservoirs. CCS in this project is claimed to be both technically feasible and cost effective compared to other climate mitigation measures to meet the Netherlands climate goals (Rotterdam CCUS, 2019). There are many concerning questions that arise in regards to the use of CCS, such as what happens if CCS capacity is not available at a certain time (e.g. due to unexpected maintenance)? Tata Steel does not consider it feasible to invest in a CCS infrastructure themselves (Van der Meulen & Leerentveld, 2019). And as mentioned at the start of this chapter, if society is not willing to accept such a project then this may put an end to the idea completely. Something that has already happened to onshore CCS in the Netherlands and Germany.

CO₂ capture and utilisation

CCS can be complimented with CCU by alleviating some of the burden from storage and creating products of value, forming a more circular economy. Nouryon (formerly AkzoNobel Speciality Chemicals), Port of Amsterdam and Tata Steel have partnered together to study the feasibility of a hydrogen cluster in the Amsterdam region. The parties see hydrogen as an essential feedstock for CCU by combining it with emissions to make useful products for the chemical industry. The first step of the study will study the feasibility of a 100 MW water electrolyser with a H₂ production capacity of 15 kt/year alongside oxygen production for steelmaking processes at TSIJ. With renewable energy sources, the electrolysis is claimed to save up to 350 kt CO₂/year and the partner companies intend to scale up the capacity if successful. The final investment decision on the project is expected in 2021 after evaluation of the feasibility study (Port of Amsterdam, 2018). The partnership with Dow Chemical to produce naphtha from blast furnace gas, alongside CCS, is anticipated to be able to achieve a CO₂ reduction of approximately 4.5 Mt/year (Van der Meulen & Leerentveld, 2019). It is clear than not one solution is necessary to meet these goals, but a wide range of collaborations and technologies will be vital.

Biomass

There is potential to use biomass as a carbon input substitution, either completely or partially. This primarily concerns the BF, TGR-BF, HIsarna and ULCORED and has the theoretical potential to even provide negative emissions in some cases. The total energy requirement that biomass (namely charcoal or biogas) would need to cover to completely replace the carbon source (coal, coke breeze or natural gas) of these options is up to 107 PJ. To put this into perspective, the Netherlands is estimated to have a biomass potential of 270 PJ, of which 150 PJ is still unused. Of this total, it is unsure as to how much of these biomass sources are suitable for use in steelmaking and can be supplied sustainably. It is estimated that the total demand for biomass will rise to 430–600 PJ in 2030 and to 670–1470 PJ in 2050 (Strengers, Eerens, Smeets, van den Born, & Ros, 2018). Hence, it is fair to say that there would be a high reliance on imports if biomass is required as a feedstock, either partially or completely.

Steel recycling

The current production process at TSIJ does not rely on scrap steel to operate, however, EAF-based steelmaking processes do rely on it. Hence, the market for scrap steel is highly competitive between EAF-based steelmakers, leading to relatively high market prices and limited availability. The availability and price of scrap in the long-term depends on global

market development and is highly uncertain. If the price of scrap becomes more favourable in the future then those decarbonisation options that include an EAF have the opportunity to capitalise on this but are not reliant on it in the case of unfavourable prices.

Energy efficiency

Energy efficiency has been at the forefront of the Tata Steel's sustainability goals for decades and a 32% energy efficiency improvement since 1989 has been achieved. Energy efficiency measures must continue to improve, however these incremental improves are not enough alone to meet the Dutch climate goals and so step-change measures discussed throughout this report are needed instead to be prioritised.

References

- Abdul Quader, M., Ahmed, S., Ariffin Raja Ghazilla, R., Ahmed, S., & Dahari, M. (2015). A comprehensive review on energy efficient CO₂ breakthrough. *Renewable and Sustainable Energy Reviews*(50), 594-614.
- Abdul Quader, M., Ahmed, S., S, Z. D., & Nukman, Y. (2016). Present needs, recent progress and future trends of energy-efficient Ultra-Low Carbon Dioxide (CO₂) Steelmaking (ULCOS) program. (55), 537-549.
- Abspoel, M. (2018). Small introduction on the converters at the basic oxygen steel plant. Eindhoven.
- Ahman, M., Olsson, O., Vogl, V., Bjorn, N., Maltais, A., Nilsson, L. J., . . . Nilsson, M. (2018). *Hydrogen steelmaking for a low-carbon economy*. Stockholm, Sweden: Stockholm Environment Institute.
- Bieda, B., Grzesik, K., Sala, D., & Gawel, B. (2015). Life cycle inventory processes of the integrated steel plant (ISP) in Krakow, Poland—coke production, a case study. *20*(8).
- Birat, J.-P. (2010). ULCOS program: status & progress. Brussels.
- Bocin-Dumitriu, A., Perez Fortes, M., Tzimas, E., & Sveen, T. (2013). *Carbon Capture and Utilisation Workshop - Background and proceedings*. Petten: European Commission.
- Brownsort, P. (2013). *Briefing: CCS for Industrial Sources of CO₂ in Europe*. Scottish Carbon Capture & Storage.
- CBS. (2017). *Energy balance; supply and consumption, sector*. Retrieved from CBS StatLine: <https://opendata.cbs.nl/statline/#/CBS/nl/dataset/83989NED/table?dl=2058D>
- Coenen, P. W., van der Maas, C. W., Zijlema, P. J., Arets, E. J., Baas, K., van den Berghe, A. C., . . . Dellaert, S. (2017). *Greenhouse gas emissions in the Netherlands 1990 - 2015 - National Inventory Report 2017*. Bilthoven: RIVM.
- CPB & PBL. (2016). *Klimaat and Energie Achtergronddocument - Toekomstverkenning 2030 en 2050*. The Hague: CPB & PBL.
- Croezen, H., & Korteland, M. (2010). *A long-term view of CO₂ efficient manufacturing in the European region*. Delft: CE Delft.
- Daniels, B. (2002). *Transition Paths towards CO₂ Emission Reduction in the Steel Industry*. Groningen, Netherlands: Rijksuniversiteit Groningen.
- Danloy, G., van der Stel, J., & Schmöle, P. (2008). Heat and mass balances in the ULCOS Blast Furnace. *Proceedings of the 4th Ulcoss seminar*.
- De Ingenieur. (2018). *TATA STEEL AND DOW TO INVEST IN GREEN CHEMICALS*. Retrieved 03 15, 2019, from De Ingenieur: <https://www.deingenieur.nl/artikel/tata-steel-and-dow-to-invest-in-green-chemicals>
- Dutch Emissions Authority. (2019). *Emissiecijfers 2013-2018*. Retrieved June 2019, from nea: <https://www.emissieautoriteit.nl/documenten/publicatie/2019/04/04/emissiecijfers-2013-2018>
- EIPPCB. (2013). *Best Available Techniques (BAT) Reference Document for Iron and Steel Production*. Seville, Spain: European Commission.
- Energy Institute. (2013). *Hazard analysis for offshore carbon capture platforms and offshore pipeline*. London: Energy Institute.
- Engineering Toolbox. (n.d.). *Fuels - Higher and Lower Calorific Values*. Retrieved 06 2019, from Engineering Toolbox: https://www.engineeringtoolbox.com/fuels-higher-calorific-values-d_169.html
- Eurofer. (2016). *Steel, the Backbone of Sustainability in Europe*. Brussels: Eurofer.
- European Commission. (2016). *Iron production by electrochemical reduction of its oxide for high CO₂ mitigation*. Luxembourg: European Union.

- European Environmental Agency. (n.d.). *Reported data on large combustion plants covered by the Industrial Emissions Directive (2010/75/EU)*. Retrieved 2 2019, from European Environmental Agency: <https://www.eea.europa.eu/data-and-maps/data/lcp-7>
- Farrer, J. (2004). *The Alloy Tree: A Guide to Low-Alloy Steels, Stainless Steels, and Nickel-base Alloys*. Woodhead Publishing.
- Feta, A., van den Broek, M., & Crijns-Graus, W. (2018). Technical demand response potentials of the integrated. *Energy Efficiency*, 1211-1225.
- Feta, A., Van Den Broek, M., Crijns-Graus, W., & Jägers, G. (2018). Technical demand response potentials of the integrated steelmaking site of Tata Steel in IJmuiden. *Energy Efficiency*, 11, 1211-1225.
- Gao, C., Ge, Q., & Jian, L. (2014). Rule Extraction From Fuzzy-Based Blast Furnace SVM Multiclassifier for Decision-Making. *IEEE Transactions on Fuzzsy Systems*, 22(3), 586-596.
- Gazzani, M., Romano, M. C., & Manzolini, G. (2015). CO2 capture in integrated steelworks by commercial-ready technologies and SEWGS process. *International Journal of Greenhouse Gas Control*, 249-267.
- Generalic, E. (2018, 10 20). *Blast furnace*. (KTF-Split) Retrieved 01 14, 2019, from Croatian-English Chemistry Dictionary & Glossary: <https://glossary.periodni.com/glossary.php?en=blast+furnace>
- Gielen, D. J., & Van Dril, A. W. (1997). *THE BASIC METAL INDUSTRY AND ITS ENERGY USE - Prospects for the Dutch energy intensive industry*. Petten, Netherlands: ECN.
- Global CCS Institute. (2010, 09 09). *CCS for the Steel sector*. Retrieved 01 22, 2019, from Global CCS Institute: <https://hub.globalccsinstitute.com/publications/global-technology-roadmap-ccs-industry-steel-sectoral-report/ccs-steel-sector>
- Greenhouse Gas Protocol. (2019). *FAQ*. Retrieved 03 05, 2019, from Greenhouse Gas Protocol: https://ghgprotocol.org/sites/default/files/standards_supporting/FAQ.pdf
- Hoa, M. T., Bustamantea, A., & Wileya, D. E. (2013). Comparison of CO2 capture economics for iron and steel mills. *International Journal of Greenhouse Gas Control*, 19, 145-159.
- Hölling, M., & Gellert, S. (2018). Direct Reduction: Transition from Natural Gas to Hydrogen?
- Hughes, S. E. (2009). *A Quick Guide to Welding and Weld Inspection*. Woodhead Publishing.
- HYBRIT. (2019). *HYBRIT – towards fossil-free steel*. Retrieved 03 18, 2019, from HYBRIT: <http://www.hybritdevelopment.com/>
- ICF Consulting Services Limited and Fraunhofer ISI. (2019). *Industrial Innovation: pathways to deep decarbonisation of industry. Part 1: Technology Analysis*. DG CLIMA.
- IEA. (2019). *IEA Technology Roadmap - The global iron and steel sector*. IEA.
- Jägers, G., & Kiesewetter, H. (2018). Sustainable development in Steel Industry. IJmuiden, Netherlands.
- Junjie, Y. (2018). Progress and Future of Breakthrough Low-carbon Steelmaking Technology (ULCOS) of EU. *International Journal of Mineral Processing and Extractive Metallurgy*, 3(2), 15-22.
- Krishnan, S. (2017). *PROJECTING THE EU'S END USE SECTOR STEEL DEMAND TILL 2050 TO INVESTIGATE THE SHARE OF HIGH & LOW STEEL GRADES AND BOLSTER DECISION MAKING IN PRODUCTION PATHWAYS*. Utrecht: University of Utrecht.
- Leung, D. Y., Caramanna, G., & Maroto-Valer Mercedes, M. (2014, Aug). An overview of current status of carbon dioxide capture and storage technologies. *Renewable and Sustainable Energy Reviews*(39), 426-443.
- Moseley, P. T., & Garcke, J. (2014). *Electrochemical Energy Storage for Renewable Sources and Grid Balancing*. Elsevier.
- Norgate, T., Haque, N., Somerville, M., & Jahanshahi, S. (2012, Feb). Biomass as a Source of Renewable Carbon for Iron and Steelmaking. *ISIJ International*, 52(8), 1472-1481.

- Pardo, N., Moya, J. A., & Vatopoulos, K. (2012). *Prospective Scenarios on Energy Efficiency and CO2 Emissions in the EU Iron & Steel Industry*. European Commission Joint Research Centre.
- Peeters, T. (2013, June). HISarna, a Revolution in Steelmaking. Brussels. Retrieved July 2019
- Peletiri, S. P., Rahmanian, N., & Mujtaba, I. M. (2018). CO2 Pipeline design: A review. *Energies*, 11.
- Port of Amsterdam. (2018). *Nouryon, Tata Steel, and Port of Amsterdam partner to develop the largest green hydrogen cluster in Europe*. Retrieved 18 03, 2019, from Port of Amsterdam: <https://www.portofamsterdam.com/en/press-release/nouryon-tata-steel-and-port-amsterdam-partner-develop-largest-green-hydrogen-cluster>
- Process Control. (2018, 11 25). *Tata steel HISarna to India instead of IJmuiden*. Retrieved 12 11, 2018, from Process Control: <https://www.processcontrol.nl/tata-steel-hisarna-naar-india-ipv-ijmuiden/>
- R. J. Fruehan, A. S. (1998). *The Making, Shaping, and Treating of Steel: Steelmaking and refining volume* (11 ed.). Pittsburgh: The AISE Steel Foundation.
- Rochelle, G. T. (2009). Amine Scrubbing for CO2 Capture. *Science*, 1652-1654.
- Rotterdam CCUS. (2019). *The Project*. Retrieved 03 18, 2019, from Rotterdam CCUS: <https://rotterdamccus.nl/en/>
- Sikstrom, P. (2013). ULCORED Direct Reduction Concept for ULCOS - a brief introduction.
- Strengers, B., Eerens, H., Smeets, W., van den Born, G. J., & Ros, J. (2018). *NEGATIEVE EMISSIES - Technisch potentieel, realistisch potentieel en kosten voor Nederland*. Den Haag: Planbureau voor de Leefomgeving.
- Suopajarvi, H. (2014). *Bioreducer use in blast furnace ironmaking in Finland techno-economic assessment and CO2 emission reduction potential*. Oulu: University of Oulu.
- Suopajarvi, H., Umeki, K., Mousa, E., Hedayati, A., Romar, H., Kemppainen, A., . . . Fabritius, T. (2018). Use of biomass in integrated steelmaking – Status quo, future needs and comparison to other low-CO2 steel production technologies. *Applied Energy*, 213, 384–407.
- Tata Steel. (2016). *Sustainability Report - Tata Steel in the Netherlands*. IJmuiden, Netherlands: Tata Steel Europe.
- Tata Steel. (2017). *Tata Steel IJmuiden BV - Report & Accounts 2017*. Tata Steel. Retrieved from <https://www.tatasteel.com/media/3805/135-tata-steel-ijmuiden-bv.pdf>
- Tata Steel. (2018, June). Email conversation.
- Tata Steel. (2018). *HISARNA: GAME CHANGER IN THE STEEL INDUSTRY*. Retrieved 12 11, 2018, from Tata Steel: https://www.tatasteeeurope.com/static_files/Downloads/Corporate/About%20us/hisarna%20factsheet.pdf
- Tata Steel. (2018). *Strip products and services catalogue 2018*. Retrieved 03 13, 2019, from Tata Steel Europe: https://www.tatasteeeurope.com/static_files/Downloads/General%20Industry%20Strip/Strip%20Products/English/Tata%20Steel%20strip%20product%20range%20catalogue%202018.pdf
- Tata Steel. (2018, 11 23). *Tata Steel to continue discussions with the European Commission on the proposed joint venture with thyssenkrupp*. Retrieved from Tata Steel: <https://www.tatasteeeurope.com/en/news/news/tata-steel-to-continue-discussions-with-the-european-commission-on-the-proposed-joint-venture-with-thyssenkrupp>
- Tata Steel. (2019). *Products*. Retrieved 03 12, 2019, from Tata Steel: <https://www.tatasteeeurope.com/en/products>
- Tata Steel. (2019). *Tata Steel in Europe*. Retrieved 03 12, 2019, from Tata Steel: https://www.tatasteeeurope.com/static_files/Archive/Old%20StaticFiles/Tata%20Steel%20In%20Europe%20Factsheet%20ENG.pdf

- Tata Steel. (2019). *The World Economic Forum recognises Tata Steel steelmaking plant as a 'factory of the future'*. Retrieved 03 30, 2018, from Tata Steel: <https://www.tatasteeleurope.com/en/news/news/the-world-economic-forum-recognises-tata-steel-steelmaking-plant-as-a-factory-of-the-future>
- Tata Steel Europe. (2016). *Sustainable Steel*. Retrieved 01 11, 2019, from KIVI Engineering Society: [https://www.kivi.nl/uploads/media/56b763ff3f7eb/Kivi%20Sustainable%20steel%20\(Hans%20Kiesewetter\)%20v6-1.pdf](https://www.kivi.nl/uploads/media/56b763ff3f7eb/Kivi%20Sustainable%20steel%20(Hans%20Kiesewetter)%20v6-1.pdf)
- Tata Steel Europe. (2018). *Tata Steel in Europe*. Retrieved 01 11, 2019, from Tata Steel Europe: https://www.tatasteeleurope.com/static_files/Downloads/Corporate/Tata%20Steel%20In%20Europe%20Factsheet%20ENG.pdf
- TenneT. (2018). *Market Review 2017 - Electricity market insights*. Retrieved 03 12, 2019, from ENSOC: <https://www.ensoc.nl/files/20180405-market-review-2017-bron-tennet.pdf>
- The Guardian. (2018, 6 30). *Go-ahead given for merger of Tata Steel and Thyssenkrupp*. Retrieved from The Guardian: <https://www.theguardian.com/business/2018/jun/30/go-ahead-given-for-merger-of-tata-steel-and-thyssenkrupp>
- van Bracht, M., & Braun, J. (2018). *Dit is een achtergrondnotitie ten behoeve van de sectortafel Industrie*. Den Haag: Topsector Energie; Den Haag Centrum voor Strategische Studies.
- Van der Meulen, B., & Leerentveld, N. (2019, 01 29). MIDDEN project discussion. IJmuiden, Netherlands.
- Van der Meulen, B., & Leerentveld, N. (2019, 04 15). MIDDEN project discussion.
- van der Stel, J. (2017). *HIIsarna Smelting Reduction - A solution for sustainable hot metal production*. Petten, Netherlands.
- van der Stel, J., Hattink, M., Zeilstra, C., Hirsch, A., Janhsen, U., Sert, D., . . . Born, S. (2014). *ULCOS - top gas recycling blast furnace process*. Brussels: European Commission.
- van der Stel, J., Meijer, K., Teerhuis, C., Zeijlstra, C., Keilman, G., & Ouweland, M. (2013). *Update to the developments of HIIsarna - An UlcOs alternative ironmaking process*. Tokyo.
- Vattenfall. (2019). *IJmond*. Retrieved 6 2019, from Vattenfall: <https://powerplants.vattenfall.com/ijmond>
- Vattenfall. (2019). *Velsen*. Retrieved June 2019, from Vattenfall: <https://powerplants.vattenfall.com/en/velsen>
- World Steel Association. (2018, 03). *Fact Sheet - Steel industry co-products*. Retrieved from World Steel Association: https://www.worldsteel.org/en/dam/jcr:1b916a6d-06fd-4e84-b35d-c1d911d18df4/Fact_By-products_2016.pdf
- World Steel Association. (2018). *STEEL STATISTICAL YEARBOOK 2018*. Brussels: World Steel Association.
- World Steel Association. (2018). *WORLD STEEL IN FIGURES 2018*. Retrieved 03 18, 2019, from World Steel: <https://www.worldsteel.org/en/dam/jcr:f9359dff-9546-4d6b-bed0-996201185b12/World+Steel+in+Figures+2018.pdf>
- Worrell, E., Price, L., Neelis, M., Galitsky, C., & Nan, Z. (2007). *World Best Practice Energy Intensity Values*. Berkeley: Environmental Energy Technologies Division - Lawrence Berkeley National Laboratory.
- Wörtler, M., Schuler, F., Voigt, N., Schmidt, T., Dahlmann, P., Bodo Lungen, H., & Ghenda, J.-T. (2013). *Steel's Contribution to a Low-Carbon Europe 2050*. The Boston Consultancy Group & Steel Institute VDEh.
- Zijlema, P. J. (2017). *Nederlandse lijst van energiedragers en standaard CO2 emissiefactoren, versie januari 2017*. The Hague: Rijksdienst voor Ondernemend.

Appendix A – current steelmaking process calculations

A1. Material and energy calculations for current steel production process

This section intends to explain the calculations and assumptions for data unverified by Tata Steel IJmuiden, these values are coloured in black font in the material and energy balances in Figure 4 and Figure 5. For flows that can be classified as both a weight/volume and as an energetic value, Table 11 displays the energy density values that allows for conversion between these units. Hence, it is only necessary to explain the calculations below in one of the interchangeable units. The energy and material flows are calculated to match as best as possible the data reported by (CBS, 2017) in 2017 as detailed in Table 12 and Table 13.

Table 11. Energy density of fuels used in the current steelmaking processes

Name	Value	Unit	Reference
BFG	3.7	MJ/Nm ³	(Feta, Van Den Broek, Crijns-Graus, & Jägers, 2018)
BOFG	8	MJ/Nm ³	(Feta, Van Den Broek, Crijns-Graus, & Jägers, 2018)
COG	19	MJ/Nm ³	(Feta, Van Den Broek, Crijns-Graus, & Jägers, 2018)
Natural gas	31.65	MJ/Nm ³	(Coenen, et al., 2017)
Coke breeze	28.5	MJ/kg	(Coenen, et al., 2017)
Coking coal	28.7	MJ/kg	(Coenen, et al., 2017)
Pulverized coal	28.7	MJ/kg	(Coenen, et al., 2017) ¹³
Oil	42.7	MJ/kg	(Zijlema, 2017)
Coal Tar	41.9	MJ/kg	(Zijlema, 2017)
BTX ¹⁴	42.7	MJ/kg	(Zijlema, 2017)

¹³ Assumed same value as coking coal

¹⁴ Classified in source under *other petroleum products*

Table 12. Energy balance of manufacture of coke oven products

Label	Cokes	COG	Electricity	BFG	Coal	Total
Total Primary Energy Supply	-59	-10	0.3	1.8	78.8	11.9
Receipts of energy	0	0	0.3	1.8	83.6	85.7
Deliveries of energy	59	10	0	0	0	69
Energy sector own use	0	5.9	0.3	1.8	0	8
Other transformation input	0	0	0	0	78.8	78.8
Total net energy transformation	-59	-15.9	0	0	78.8	3.9
Other transformation output	59	15.9	0	0	0	74.9
Total energy consumption	-59	-10	0.3	1.8	78.8	11.9
Stock change	0	0	0	0	-4.8	-4.8
Total	-59	-4.1	1.2	7.2	394	339.3

Table 13. Energy balance of iron & steel industry

Label	Natural gas	Cokes	COG	Electricity	Oil	BFG	Coal	Heat	Total
Total Primary Energy Supply	11.4	55.2	8.3	8.8	0.2	-24.9	47	0	105.95
Receipts of energy	11.7	57.9	10	11.6	0.2	0	48.1	0	139.45
Deliveries of energy	0.3	5	1.7	2.8	0	24.9	0	0	34.7
Final energy consumption	10	0.1	7.9	9.3	0.2	10	0	2.8	40.3
Electricity and CHP transformation input	1.3	0	0.4	0	0	2.1	0	0	3.8
Other transformation input	0	55.1	0	0	0	0	47	0	102.1
Net electricity/CHP transformation	1.3	0	0.4	-0.5	0	2.1	0	-2.8	0.5
Net other transformation	0	55.1	0	0	0	-37	47	0	65.1
Electricity/CHP transformation output	0	0	0	0.6	0	0	0	2.8	3.4
Other transformation output	0	0	0	0	0	37	0	0	37
Total energy consumption	11.4	55.2	8.3	8.8	0.2	-24.9	47	0	106
Stock change	0	2.3	0	0	0	0	-1.1	0	1.2
Total	47.3	285.9	37	41.4	0.8	-10.7	235	2.8	639.5

Coke breeze INPUT TO sinter plant

Value = 0.16 Mt

Assumption: Based on (EIPPCB, 2013) the average ratio of coke breeze used in the sinter plant to pellet plant is 3.7:1 respectively. It is known that 0.2 Mt of coke breeze is produced from the coke plant and hence it can be derived that 0.16 Mt and 0.04 Mt coke breeze are inputted to the sinter plant and pellet plant respectively.

Natural gas INPUT TO sinter plant

Value = 0.19 PJ

Assumption: Tata Steel IJmuiden verified that the natural gas usage in the 'heavy side' (pellet plant, sinter plant and blast furnace) is 0.7 PJ. Based on (EIPPCB, 2013) the ratio of average natural gas consumption of the pellet plant, sinter plant and blast furnace is 1:4.8:12 respectively. The total use of 0.7 PJ is divided among these processes in this ratio.

Coke breeze **INPUT TO** pellet plant

Value = 0.04 Mt

Assumption: Based on (EIPPCB, 2013) the average ratio of coke breeze used in the sinter plant to pellet plant is 3.73:1 respectively. It is known that 0.2 Mt of coke breeze is produced from the coke plant and hence it can be derived that 0.16 Mt and 0.04 Mt coke breeze are used in the sinter plant and pellet plant respectively.

Natural gas **INPUT TO** pellet plant

Value = 0.04 PJ

Assumption: Tata Steel IJmuiden verified that the natural gas usage in the 'heavy side' (pellet plant, sinter plant and blast furnace) is 0.7 PJ. Based on (EIPPCB, 2013) the ratio of average natural gas consumption of the pellet plant, sinter plant and blast furnace is 1:4.8:12 respectively. The total use of 0.7 PJ is divided among these processes in this ratio.

Blast furnace gas **INPUT TO** blast furnace

Value = 8.80 PJ

Assumption: (CBS, 2017) states that 10 PJ of BFG and BOFG is reused within the process (excluding coke production) and Tata Steel IJmuiden verified that 1.10 PJ of BOFG is inputted into the pellet plant, and 0.10 PJ of BFG is flared and hence the remainder is assumed to be utilized in the blast furnace.

Natural gas **INPUT TO** blast furnace

Value = 0.47 PJ

Assumption: Tata Steel IJmuiden verified that the natural gas usage in the 'heavy side' (pellet plant, sinter plant and blast furnace) is 0.7 PJ. Based on (EIPPCB, 2013) the ratio of average natural gas consumption of the pellet plant, sinter plant and blast furnace is 1:4.8:12 respectively. The total use of 0.7 PJ is divided among these processes in this ratio.

Coke oven gas **INPUT TO** blast furnace

Value = 1.70 PJ

Assumption: (CBS, 2017) states that the total final consumption of COG is 9.7 PJ in the steelmaking processes (excluding coke production). Tata Steel IJmuiden have verified that 6.2 PJ and the remainder is assumed to be consumed in the blast furnace.

Oxygen **INPUT TO** blast furnace

Value = 5.23×10^8 Nm³

Assumption: based on (EIPPCB, 2013), an average value of oxygen consumption in 'tuyere injection' and 'other' is taken.

Oxygen **INPUT TO** basic oxygen furnace

Value = 3.74×10^8 Nm³

Assumption: based on (EIPPCB, 2013), an average value of oxygen is taken.

Air **INPUT TO** oxygen production

Value = 4.75×10^9 Nm³

Assumption: calculated backwards from oxygen requirements (blast furnace, basic oxygen furnace) assuming 90% conversion efficiency and 21% oxygen content in air.

Nitrogen **OUTPUT OF** oxygen production

Value = 3.33×10^9 Nm³

Assumption: 90% efficiency and 78vol% of N₂ in air

Natural gas **INPUT TO** downstream steelmaking processes

Value = 8.00 PJ

Assumption: Tata Steel IJmuiden verified that the natural gas usage in the 'light side' (classified as downstream steelmaking processes in this report) is 7.5 PJ. However, this value has been increased to meet the total natural gas usage (excluding coke production) as reported in (CBS, 2017).

Electricity **INPUT TO** sinter plant

Value = 0.46 PJ

Assumption: Based on (EIPPCB, 2013), the average consumption value is used.

Electricity **INPUT TO** pellet plant

Value = 0.36 PJ

Assumption: Based on (EIPPCB, 2013), the average consumption value is used.

Electricity **INPUT TO** blast furnace

Value = 1.67 PJ

Assumption: Based on (EIPPCB, 2013), the average consumption value is used.

Electricity **INPUT TO** basic oxygen furnace

Value = 0.69 PJ

Assumption: Based on value in (Worrell, Price, Neelis, Galitsky, & Nan, 2007).

Electricity **INPUT TO** oxygen production

Value = 1.35 PJ

Assumption: Based on MIDDEN report – production of industrial gases (Cioli & Schure, in prep.).

Electricity **INPUT TO** downstream steelmaking processes

Value = 3.97 PJ

Assumption: (CBS, 2017) states that total final electricity consumption for steelmaking processes (excluding coke production) is 9.3 PJ, hence the electricity required for downstream steelmaking processes is assumed to be the remainder from what is assumed to be used in all other processes.

Electricity **OUTPUT OF** Velsen 24

Value = 0.22 PJ

Calculation: total fuel input * efficiency of 36.3% (Tata Steel, 2018)

Electricity **OUTPUT OF** Velsen 25

Value = 6.77 PJ

Calculation: total fuel input * efficiency of 38% (Tata Steel, 2018)

Electricity **OUTPUT OF** IJmond 1

Value = 3.63 PJ

Calculation: total fuel input * efficiency of 41% (Tata Steel, 2018)

Heat **OUTPUT OF** IJmond 1

Value = 4.97 PJ

Calculation: calculated based on an electricity-to-heat ratio of 1.37 (Vattenfall, 2019).

A2. CO₂ emission data for current steel production process

Presented below are the emission factors for all relevant material and energy flows in the process (Table 14) and the carbon content of steel products (Table 15). These are used to calculate CO₂ emissions of each process as detailed in section 3.2.

Table 14. Emission factors for steelmaking fuels and materials

Fuel/material	Value	Unit	Reference
BFG	247.4	kg-CO ₂ /GJ	(Zijlema, 2017)
COG	42.8	kg-CO ₂ /GJ	(Zijlema, 2017)
BOFG	191.9	kg-CO ₂ /GJ	(Zijlema, 2017)
Natural Gas	56.6	kg-CO ₂ /GJ	(Zijlema, 2017)
Coke/coke breeze	89.8	kg-CO ₂ /GJ	(Zijlema, 2017)
Oil ¹⁵	73.3	kg-CO ₂ /GJ	(Zijlema, 2017)
Coking coal	95.4	kg-CO ₂ /GJ	(Zijlema, 2017)
Pulverized coal	98.3	kg-CO ₂ /GJ	(Zijlema, 2017)
Limestone	0.44	kg-CO ₂ /kg-CaCO ₃	(Coenen, et al., 2017)
Dolomite	0.48	kg-CO ₂ /kg-dolomite	(Coenen, et al., 2017)
Coal tar	80.7	kg-CO ₂ /GJ	(Zijlema, 2017)
BTX	73.3	kg-CO ₂ /GJ	(Zijlema, 2017)

Table 15. Carbon content of steelmaking products

Material	Assumed value	Unit	Reference
Pig iron	0.04	wt-C/wt	(EIPPCB, 2013)
Crude steel	0.0004	wt-C/wt	(R. J. Fruehan, 1998)
Scrap steel	0.0009	wt-C/wt	(R. J. Fruehan, 1998)
DRI/HBI	0.02	wt-C/wt	(EIPPCB, 2013)
Carbon steel	0.003	wt-C/wt	(Hughes, 2009)
Stainless steel	0.01	wt-C/wt	(Farrer, 2004)

¹⁵ Gas/diesel oil.